

4 | 3 | 2 | 1

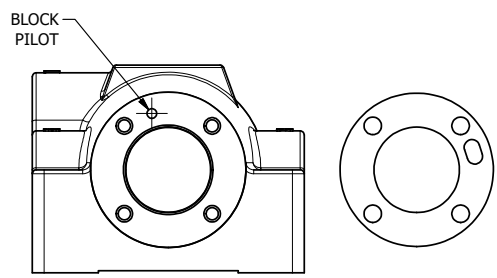
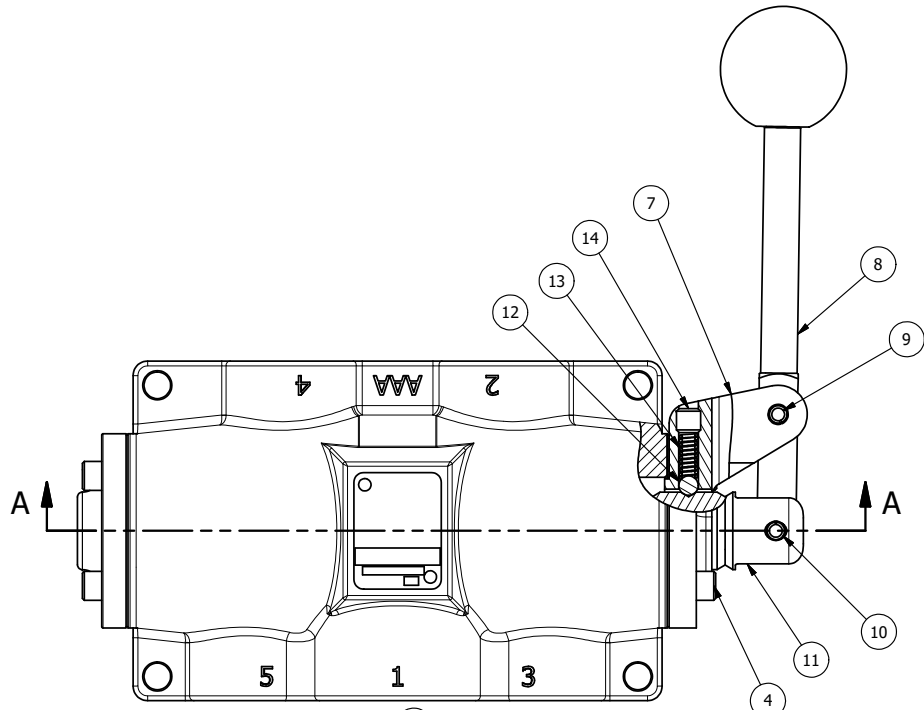

POSITION GASKET ON END OF VALVE SO GASKET COVERS PILOT HOLE BOTH SIDES (SIDE 'A' SHOWN)

NOTES:  
 1) ALWAYS GIVE VALVE MODEL AND PART NUMBER WHEN ORDERING PARTS.  
 2) LUBRICATE SPRINGS, AND DETENT BALL.

|     |     |         |  |
|-----|-----|---------|--|
| 16  | 2   | V-212   | SCREW, #2 X 3/16 DRIVE, TYPE U, OVAL HEAD, STAINLESS STEEL                   |
| 15  | 1   | AN-114  | NAME PLATE, BLANK, FOR VALVES WITH SPRINGS OR DETENTS.                       |
| 14  | 1   | V-8     | SCREW, 5/16-18 X 5/16, SOCKET SET, CUP POINT                                 |
| 13  | 1   | DS48    | SPRING - DETENT, 1/2", 3/4" & 1" VALVE                                       |
| 12  | 1   | V-4     | BALL, CHROME STEEL 1/4 DIA. FOR DETENT                                       |
| 11  | 1   | SC8-3   | CLEVIS - 3 POS. DETENT, 3/4" & 1" VALVE                                      |
| 10  | 1   | V-51-SS | PIN, ROLL 1/4 X 1 FOR 3/4 & 1" HAND FOOT & CAM VALVES, STAINLESS STEEL       |
| 9   | 1   | V-70    | PIN, ROLL 1/4 X 1 1/8 FOR 3/4 & 1" HAND AND FOOT VALVES                      |
| 8   | 1   | HL8-9   | HAND LEVER ASSEMBLY, 3/4" & 1" VALVE   |
| 7   | 1   | FEB-3   | END CAP, HAND & FOOT, DETENT, STEEL, NICKEL PLT, 3/4" & 1" VALVES            |
| 6   | 1   | SSH8G   | SPOOL - 'G', 3 POS, FLOAT CTR, 3/4" & 1" VALVE                               |
| 5   | 1   | PEC48-3 | END CAP, VENTED, 380 AL, 1/2", 3/4" & 1" VALVES                              |
| 4   | 8   | V-46    | SCREW, 1/4-20 X 3/4, SOCKET HEAD CAP   |
| 3   | 2   | ECG48   | GASKET - END CAP, 1/2", 3/4" & 1" VALVE                                      |
| 2   | 6   | V-30    | O-RING, BUNA-N, 70 DURO, AS-220, (REF 1-3/8 X 1-5/8 X 1/8), 3/4" & 1" VALVES |
| 1   | 1   | B6-1    | BODY, 3/4" SIDE PORT, UPPER PILOTS, ANODIZED                                 |
| FLG | QTY | PART NO | DESCRIPTION  |

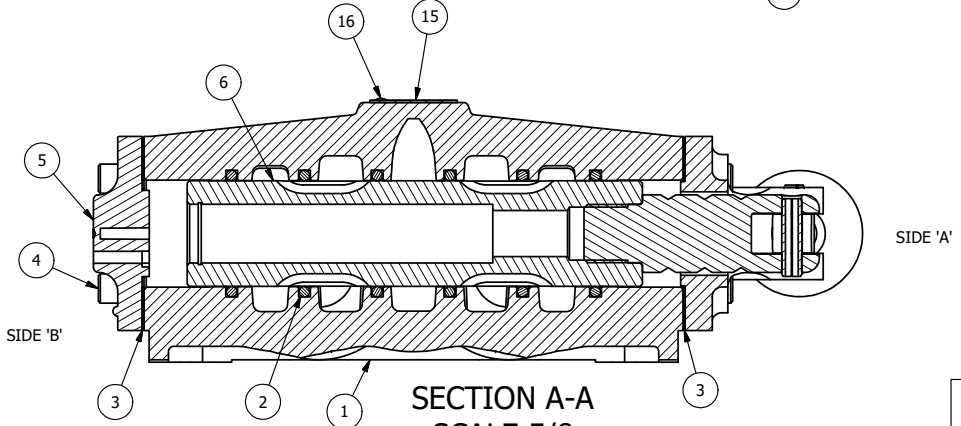

SECTION A-A  
 SCALE 5/8  
 VIEW FROM 3 PORT SIDE

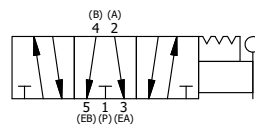

|  |                 |  |                    |  |
|--|-----------------|--|--------------------|--|
| LIMITS ON DIMENSIONS<br>UNLESS OTHERWISE SPECIFIED                                   |                 | 2-PL DECIMAL ± .01<br>3-PL DECIMAL ± .005<br>FRACTIONAL ± 1/64<br>ANGULAR ± 1/2° |                    | <b>AAA PRODUCTS INTERNATIONAL</b><br>7114 Harry Hines Blvd<br>Dallas, TX 75235 |
| DRAWN: RMckenna  | DATE: 9/10/2015 | CHECKED: KWaite  | DATE: 9/10/2015    |  |
| SCALE: 3/4   | SHEET: 1 OF 1   | RELEASED: HWomack  | DATE: 9/10/2015    |  |
| TITLE:<br>3/4" SIDE PORT, LEVER, 3 POS, DETENT, LEVER SHFT, FLOAT CTR SPL, 90D LEVER |                 |  | PART NO.:<br>HD6GR | REV.:  |

THE INFORMATION CONTAINED WITHIN THIS DOCUMENT IS PROPRIETARY TO AAA PRODUCTS AND MAY NOT BE DISCLOSED WITHOUT PRIOR WRITTEN CONSENT

4 | 3 | 2

P:\Engineering\product\Valve Assembly\Lever\HD6GR.dwg