

BLOCK PILOT

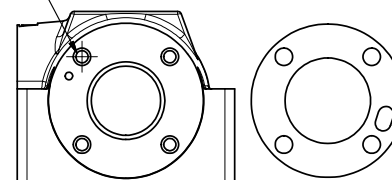

POSITION GASKET ON END OF VALVE SO GASKET COVERS PILOT HOLE BOTH SIDES (SIDE 'A' SHOWN)

NOTES:
 1) ALWAYS GIVE VALVE MODEL AND PART NUMBER WHEN ORDERING PARTS.
 2) LUBRICATE DETENT BALL, SPRING AND CLEVIS.

17	1	SPK-4	KIT - SUBPLATE MOUNT, 1/2" SUBPLATE VALVES
16	2	V-212	SCREW, #2 X 3/16 DRIVE, TYPE U, OVAL HEAD, STAINLESS STEEL
15	1	AN-114	NAMEPLATE, BLANK, FOR VALVES WITH SPRINGS OR DETENTS
14	1	V-8	SCREW, 5/16-18 X 5/16, SOCKET SET, CUP POINT
13	1	DS48	SPRING - DETENT, 1/2", 3/4" & 1" VALVE
12	1	V-4	BALL, CHROME STEEL 1/4 DIA. FOR DETENT
11	1	SC4-3	CLEVIS - 3 POS. DETENT, 1/2" VALVE
10	1	V-7	PIN, ROLL 3/16 X 11/16, STEEL, FOR 1/4 THRU 1/2" HAND, FT & CAM V
9	1	V-10	PIN, ROLL 3/16 X 7/8, STEEL
8	1	HL4-9C	HAND LEVER ASSEMBLY, CURVED LEVER, 1/2" VALVE
7	1	FE4-3	END CAP - HAND & FOOT, DETENT, 380 AL, 1/2" VALVE
6	1	SSH4D	SPOOL - 'D', 3 POS, REGEN CTR, 1/2" VALVE
5	1	PEC48-3	END CAP, VENTED, 380 AL, 1/2", 3/4" & 1" VALVES
4	8	V-46	SCREW, 1/4-20 X 3/4, SOCKET HEAD CAP
3	2	ECG48	GASKET - END CAP, 1/2", 3/4" & 1" VALVE
2	6	V-6	O-RING, BUNA-N, 70 DURO, AS-216, (REF 1-1/8 X 1-3/8 X 1/8), 1/2" VALVES, 1" SUBPLATE
1	1	BP4-1	BODY, 1/2" SUBPLATE, UPPER PILOTS, ANODIZED
FLG	QTY	PART NO	DESCRIPTION

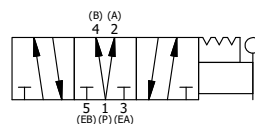
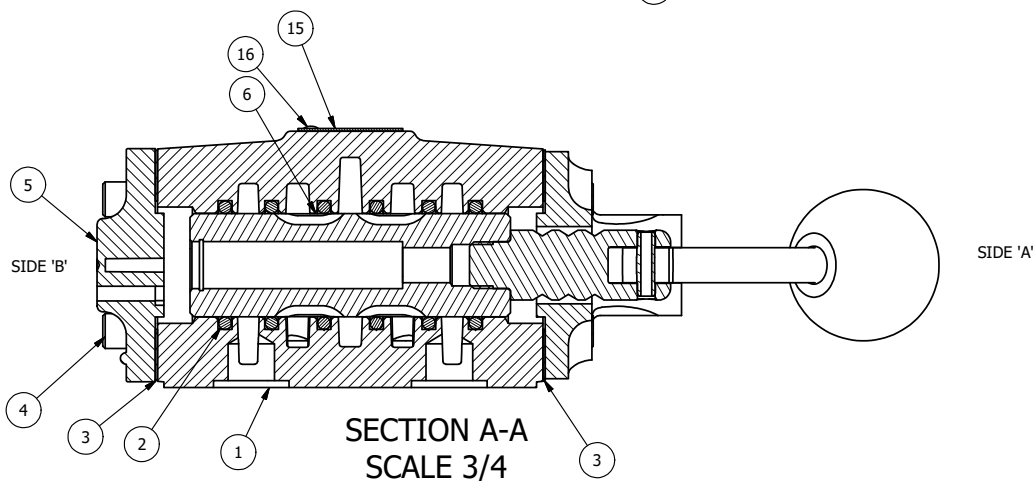

LIMITS ON DIMENSIONS
 UNLESS OTHERWISE SPECIFIED
 2-PL DECIMAL ± .01
 3-PL DECIMAL ± .005
 FRACTIONAL ± 1/64
 ANGULAR ± 1/2°

AAA PRODUCTS INTERNATIONAL
 7114 Harry Hines Blvd
 Dallas, TX 75235

DRAWN: RMckenna DATE: 12/21/2022

CHECKED: KWaite DATE: 12/21/2022

SCALE: 3/4 SHEET: 1 OF 1

RELEASED: HWomack DATE: 12/21/2022

TITLE:
 1/2" SUBPLATE, LEVER, 3 POS,
 DETENT, LEVER SHFT, REGEN CTR SPL,
 CRVD LVR, 90D LVR

PART NO.:
 HD4PDCR

THE INFORMATION CONTAINED WITHIN THIS DOCUMENT IS PROPRIETARY TO AAA PRODUCTS AND MAY NOT BE DISCLOSED WITHOUT PRIOR WRITTEN CONSENT

D:\Engineering\Products\Valves\Assembly\Level HD4\G\HD4PDCR.dwg