

POSITION GASKET ON END OF VALVE TO SEAL PILOT HOLE IF PRESENT, BOTH SIDES (SIDE 'B' SHOWN)

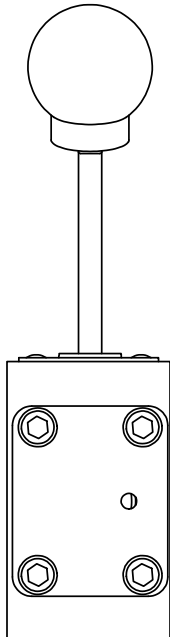

SIDE B

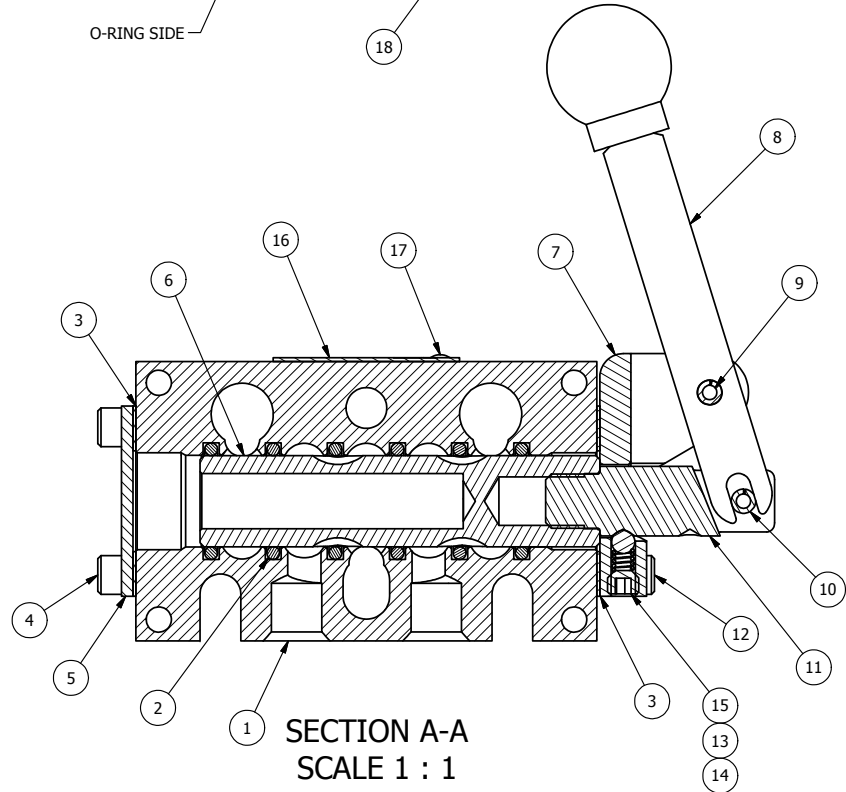

SIDE A

SECTION A-A  
SCALE 1 : 1

NOTES:  
1) ALWAYS GIVE VALVE MODEL AND PART NUMBER WHEN ORDERING PARTS.

18	3	V-110	O-RING, 5/8 X 13/16 X 3/32 BUNA 70 D. FOR 1/4 SLEEVE VALVES & STACKING MANIFOLD
17	2	V-212	SCREW, #2 X 3/16 DRIVE, TYPE U, OVAL HEAD, 316 STAINLESS STEEL
16	1	AN-114	NAME PLATE, BLANK, FOR VALVES WITH SPRINGS OR DETENTS.
15	1	V-21	SCREW, 1/4-20 X 3/16 SOCKET SET (CUP POINT)
14	1	DS3	SPRING - DETENT, 1/4" & 3/8" VALVE
13	1	V-14	BALL, CHROME STEEL 3/16 DIA. FOR DETENT
12	4	V-162	SCREW, 10-24 X 5/8 SHCS CAP R2H VALVE & JIFFY WIPER
11	1	BHC3-2	CLEVIS - A & C POS. DETENT, 1/4" & 3/8" STACKING VALVE
10	1	V-48	PIN, ROLL 3/16 X 9/16 ZINC PLATED STEEL FOR 1/4 HAND & FOOT CLEVIS
9	1	V-542	PIN, ROLL 3/16 X 1/2 ZINC PLATED STEEL FOR HE3-4 END CAP
8	1	HL3-24	HAND LEVER WITH KNOB, 1/4" & 3/8" VALVE
7	1	HE3-4D	ENDCAP - HAND, DETENT, 1/4" & 3/8" STACK VALVE
6	1	S3	SPOOL - STANDARD, 2 POS, CLSD CTR, 1/4" & 3/8" VALVE
5	1	SEC3	END CAP, STEEL, ZINC PLT, 1/4" & 3/8" VALVE
4	4	V-37	SCREW, 10-24 X 1/2 SHCS, FOR 1/8" STEEL END CAPS
3	2	ECG3	GASKET - END CAP, 1/4" & 3/8" VALVE
2	6	V-39	O-RING, STD BODY, VITON, 1/4" & 3/8" VALVES
1	1	B2-10E	FINISHED - SOLID BODY, UPPER PILOTS, 1/4" STACKING VALVE
FLG	QTY	PART NO	DESCRIPTION

LIMITS ON DIMENSIONS  
UNLESS OTHERWISE SPECIFIED  
2-PL DECIMAL ± .01  
3-PL DECIMAL ± .005  
FRACTIONAL ± 1/64  
ANGULAR ± 1/2°

**AAA PRODUCTS INTERNATIONAL**  
7114 Harry Hines Blvd  
Dallas, TX 75235

DRAWN: RHuffstetter DATE: 3/7/2002 CHECKED: KWaite DATE: 9/29/2013  
SCALE: 1 : 1 SHEET: 1 OF 1 RELEASED: HWomack DATE: 9/29/2013

TITLE: <b>1/4" STACK, LEVER, 2 POS, DETENT, LEVER RTRN</b>	PART NO.: <b>BHD2Q</b>	REV.: <b>B</b>
---	---------------------------	-------------------

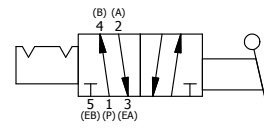

B	10/17/06	CHANGED GASKET FROM BG3 TO ECG3.
A	7/20/05	CHANGED GASKET FROM NEG3 TO BG3.
NO.	DATE	REVISION

THE INFORMATION CONTAINED WITHIN THIS DOCUMENT IS PROPRIETARY TO AAA PRODUCTS AND MAY NOT BE DISCLOSED WITHOUT PRIOR WRITTEN CONSENT

P:\Engineering\Inventory Files\Internal Drawings\Valves Assembly\Lever\YD\BHD2Q.dwg