

POSITION GASKET ON END OF VALVE TO SEAL PILOT HOLE IF PRESENT, BOTH SIDES (SIDE 'B' SHOWN)

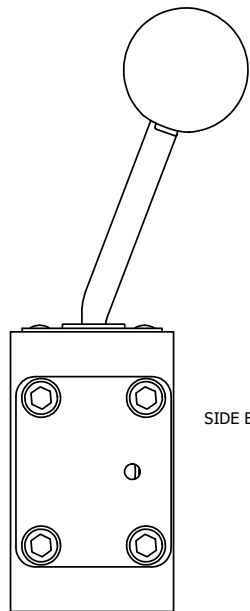

SIDE B

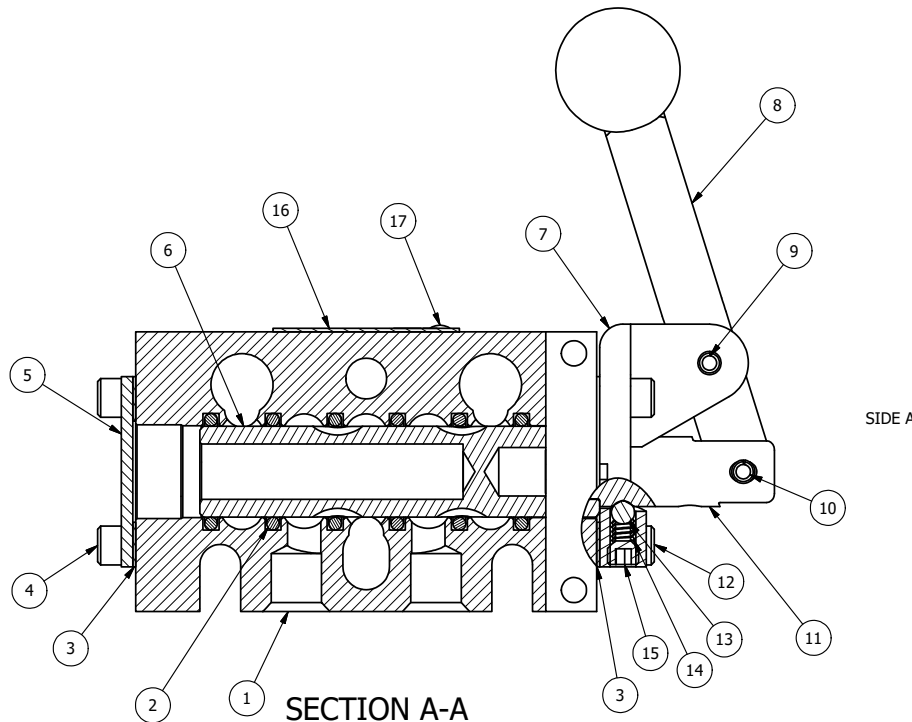

SIDE A

SECTION A-A
SCALE 1 : 1

NOTES:
1) ALWAYS GIVE VALVE MODEL AND PART NUMBER WHEN ORDERING PARTS.

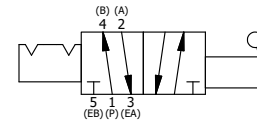

| | | | |
|-----|-----|------------|---|
| 18 | 3 | V-110 | O-RING, BUNA-N, 70 DURO, AS-114, (REF 5/8 X 13/16 X 3/32), 1/4" SLEEVE, 1/2" SUB, STACK |
| 17 | 2 | V-212 | SCREW, #2 X 3/16 DRIVE, TYPE U, OVAL HEAD, STAINLESS STEEL |
| 16 | 1 | AN-114 | NAMEPLATE, BLANK, FOR VALVES WITH SPRINGS OR DETENTS |
| 15 | 1 | V-21 | SCREW, 1/4-20 X 3/16, SOCKET SET, CUP POINT |
| 14 | 1 | DS3 | SPRING - DETENT, 1/4" & 3/8" VALVE |
| 13 | 1 | V-14 | BALL, CHROME STEEL 3/16 DIA, GRADE 25, FOR DETENT |
| 12 | 4 | V-162 | SCREW, 10-24 X 5/8, SOCKET HEAD CAP |
| 11 | 1 | BHC3-2 | CLEVIS - A & C POS. DETENT, 1/4" & 3/8" STACKING VALVE |
| 10 | 1 | V-48 | PIN, ROLL 3/16 X 9/16, STEEL, ZINC PLATED |
| 9 | 1 | V-542 | PIN, ROLL 3/16 X 1/2 ZINC PLATED STEEL FOR HE3-4 END CAP |
| 8 | 1 | HL3-521B20 | HAND LEVER WITH RED KNOB, BENT 20 DEG SIDEWAYS, 1/4" & 3/8" VALVES |
| 7 | 1 | HE3-4D | ENDCAP - HAND, DETENT, 303 STAINLESS, 1/4" & 3/8" STACK VALVE |
| 6 | 1 | S3 | SPOOL - STANDARD, 2 POS, CLSD CTR, 1/4" & 3/8" VALVE |
| 5 | 1 | SEC3 | END CAP, 304 STAINLESS STEEL, 1/4" & 3/8" VALVE |
| 4 | 4 | V-37 | SCREW, 10-24 X 1/2, SOCKET HEAD CAP |
| 3 | 2 | ECG3 | GASKET - END CAP, 1/4" & 3/8" VALVE |
| 2 | 6 | V-39 | O-RING, VITON, STD BODY, 1/4" & 3/8" VALVES |
| 1 | 1 | B2-10E | FINISHED - SOLID BODY, UPPER PILOTS, 1/4" STACKING VALVE |
| FLG | QTY | PART NO | DESCRIPTION |

LIMITS ON DIMENSIONS
UNLESS OTHERWISE SPECIFIED

2-PL DECIMAL ± .01
3-PL DECIMAL ± .005
FRACTIONAL ± 1/64
ANGULAR ± 1/2°



DRAWN: RMcKenna DATE: 12/26/2022

CHECKED: KWaite DATE: 12/26/2022

SCALE: 1 : 1 SHEET: 1 OF 1

RELEASED: HWomack DATE: 12/26/2022

TITLE:
1/4" STACK, LEVER, 2 POS,
DETENT, LEVER RTRN,
BNT LVR LFT, RED KNOB

PART NO.:
BHD2BLJQ

REV.:

THE INFORMATION CONTAINED WITHIN THIS DOCUMENT IS PROPRIETARY TO AAA PRODUCTS AND MAY NOT BE DISCLOSED WITHOUT PRIOR WRITTEN CONSENT