

MARK VALVE USING 1/8" LETTERS WHERE XX IS THE DATE CODE

- NOTES:
 1) ALWAYS GIVE VALVE MODEL, AND PART NUMBER WHEN ORDERING PARTS.
 2) USE MASTER LOCK #7LJKAP176 (ORDERED SEPERATELY, #7LJ KEYPED ALIKE - KAP176).
 3) FOR MULTIPLE LOCKS, USE LOCKOUT HASP LO23 (ORDERED SEPERATELY).

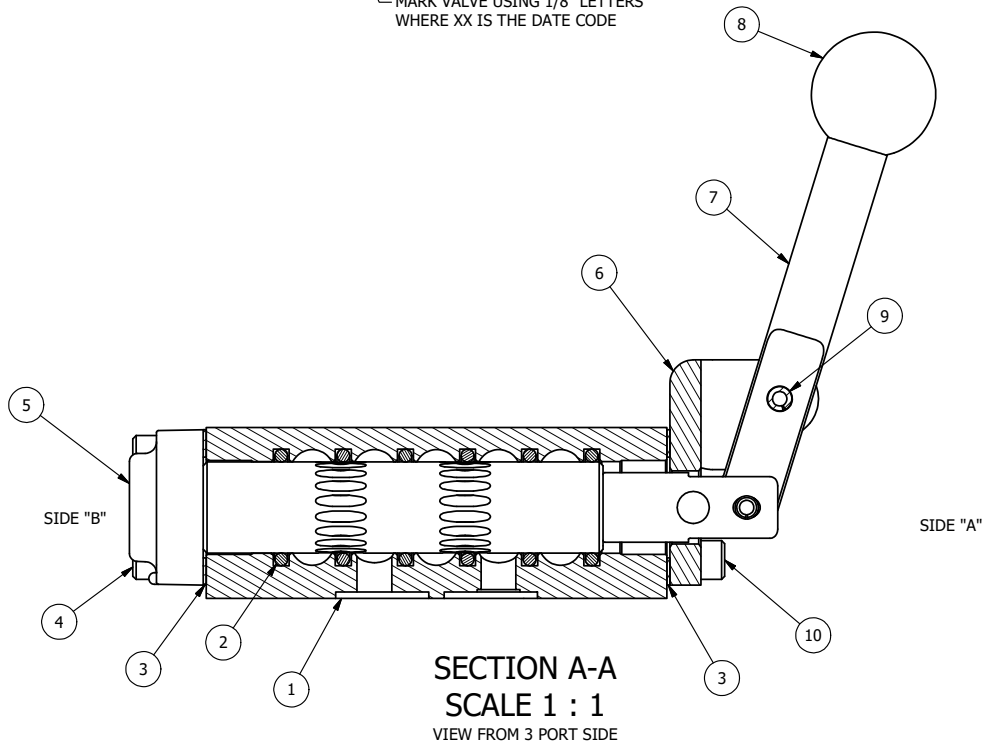

SECTION A-A
SCALE 1 : 1
 VIEW FROM 3 PORT SIDE

FLG	QTY	PART NO	DESCRIPTION
13	1	ZNSPK-2	KIT - SUBPLATE MOUNTING, BRASS NAMUR, (2 EA V-618-SS SCREW, 2 EA V-565 O-RING)
12	1	V-548	O-RING, BUNA-N, 70 DURO, 6MM X 1MM, NAMUR PLUG
11	1	V-547	PLUG, 360 HALF HARD BRASS, NAMUR VALVE
10	4	V-162-SS	SCREW, 10-24 X 5/8, SOCKET HEAD CAP, STAINLESS STEEL
9	1	V-508-SS	PIN, ROLL 3/16 X 5/8", 18-8 SS
8	1	V-521	KNOB, RED (BRASS 3/8-16 INSERT), 1" DIA BALL, 1/4" & 3/8" VALVE
7	1	HL3-SS	HAND LEVER, 303 STAINLESS STEEL, 1/4" & 3/8" VALVE
6	1	HE3-SLO	END CAP, LEVER, 303 STAINLESS, LOCKOUT, 1/4" & 3/8" VALVES
5	1	AY-HA3LO-SA	ASSY - LOCKOUT A, RTRN TO A, LEVER OR TREADLE, SS W/AL SPOOL, 1/4 & 3/8 VALVES
4	4	V-38-SS	SCREW, 10-24 X 3/4, SOCKET HEAD CAP, 18-8 SS
3	2	ECG3	GASKET - END CAP, 1/4" & 3/8" VALVE
2	6	V-39	O-RING, VITON, STD BODY, 1/4" & 3/8" VALVES
1	1	Z2-11	BODY - BRASS, UPPER PILOTS (BUTTON BLEEDER), 1/4" NAMUR

LIMITS ON DIMENSIONS UNLESS OTHERWISE SPECIFIED		2-PL DECIMAL ± .01 3-PL DECIMAL ± .005 FRACTIONAL ± 1/64 ANGULAR ± 1/2°		AAA PRODUCTS INTERNATIONAL 7114 Harry Hines Blvd Dallas, TX 75235
DRAWN: RMckenna	DATE: 10/13/2018	CHECKED: KWaitte	DATE: 10/13/2018	
SCALE: 1 : 1	SHEET: 1 OF 1	RELEASED: HWomack	DATE: 10/13/2018	
TITLE: 1/4" NAMUR, LEVER, 2 POS, RVRS SPR RTRN, BRASS & SS, RED KNOB, LOCKOUT A			PART NO.: ZNHA2JLO	REV.:

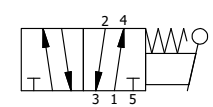

THE INFORMATION CONTAINED WITHIN THIS DOCUMENT IS PROPRIETARY TO AAA PRODUCTS AND MAY NOT BE DISCLOSED WITHOUT PRIOR WRITTEN CONSENT

D:\Engineering\product\Valves\Assemblies\Levers\1450\G\ZNHA2JLO.dwg