

4

3

2

1

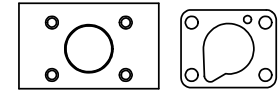
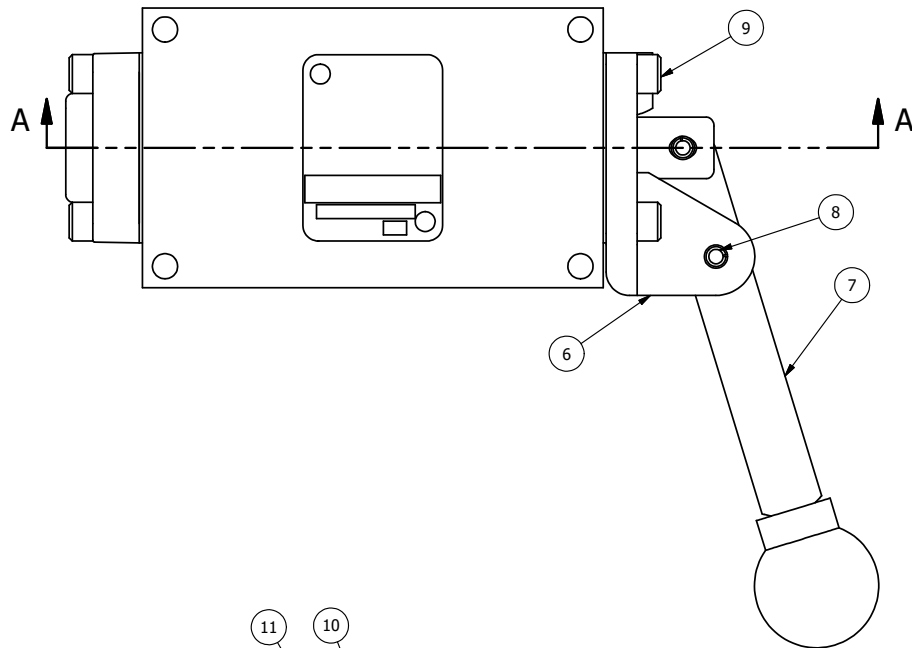

POSITION GASKET ON END OF VALVE SO
MOUNTING HOLES ALIGN
BOTH ENDS (SIDE 'A' SHOWN)

NOTES:

1) ALWAYS GIVE VALVE MODEL, AND PART NUMBER WHEN ORDERING PARTS.

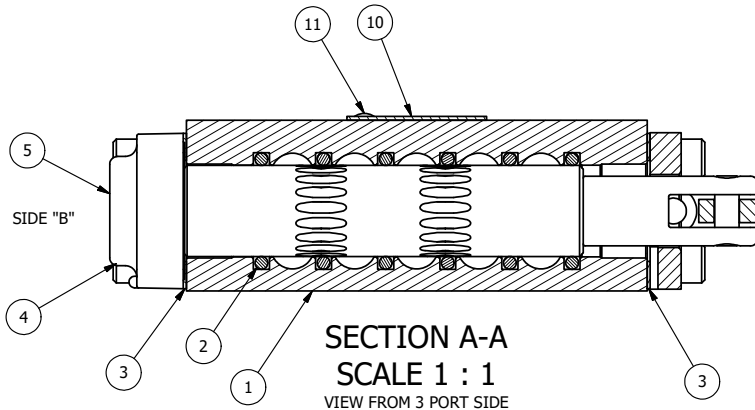

SIDE "A"

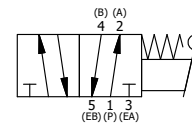

FLG	QTY	PART NO	DESCRIPTION
	2	V-212	SCREW, #2 X 3/16 DRIVE, TYPE U, OVAL HEAD, STAINLESS STEEL
	1	AN-114	NAMEPLATE, BLANK, FOR VALVES WITH SPRINGS OR DETENTS
	4	V-162	SCREW, 10-24 X 5/8, SOCKET HEAD CAP
	1	V-542	PIN, ROLL 3/16 X 1/2 ZINC PLATED STEEL FOR HE3-4 END CAP
	1	HL3-24	HAND LEVER WITH KNOB, 1/4" & 3/8" VALVE
	1	HE3-4	ENDCAP - HAND OPERATOR, 303 STAINLESS, 1/4" & 3/8" STACK VALVE
	1	AY-HA3	ASSY - NO DETENT, RTRN TO POS A, LEVER OR TREADLE, 1/4 & 3/8 VALVES
	4	V-38	SCREW, 10-24 X 3/4, SOCKET HEAD CAP
	2	ECG3	GASKET - END CAP, 1/4" & 3/8" VALVE
	6	V-39	O-RING, VITON, STD BODY, 1/4" & 3/8" VALVES
	1	B3-2E	BODY - SOLID, PLAIN, NO PILOTS, ANODIZED, 3/8" SIDE PORT VALVE

LIMITS ON DIMENSIONS UNLESS OTHERWISE SPECIFIED		2-PL DECIMAL ± .01 3-PL DECIMAL ± .005 FRACTIONAL ± 1/64 ANGULAR ± 1/2°		 AAA PRODUCTS INTERNATIONAL 7114 Harry Hines Blvd Dallas, TX 75235	
DRAWN: RMckenna	DATE: 9/7/2016	CHECKED: KWaite	DATE: 9/7/2016		
SCALE: 1 : 1	SHEET: 1 OF 1	RELEASED: HWomack	DATE: 9/7/2016		
TITLE: 3/8" SIDE PORT, LEVER, 2 POS, RVRS SPR RTRN, 270D LEVER				PART NO.:	REV.:
				HA3RT	

THE INFORMATION CONTAINED WITHIN THIS DOCUMENT IS PROPRIETARY TO AAA PRODUCTS AND MAY NOT BE DISCLOSED WITHOUT PRIOR WRITTEN CONSENT

P:\Engineering\product\Valves\Assemb\HA3RT.dwg