

POSITION GASKET ON END OF VALVE SO MOUNTING HOLES ALIGN BOTH ENDS (SIDE 'A' SHOWN)

NOTES:

1) ALWAYS GIVE VALVE MODEL, AND PART NUMBER WHEN ORDERING PARTS.

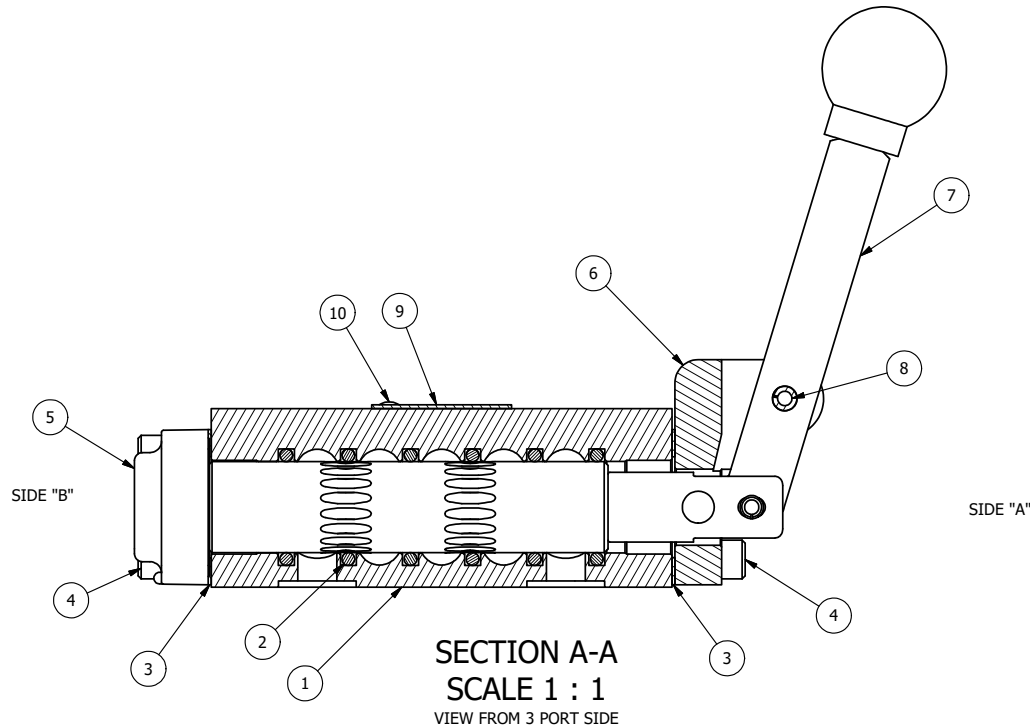

FLG	QTY	PART NO	DESCRIPTION
11	1	SPK-3	KIT - SUBPLATE MOUNTING, 3/8" SUBPLATE VALVES
10	2	V-212	SCREW, #2 X 3/16 DRIVE, TYPE U, OVAL HEAD, STAINLESS STEEL
9	1	AN-114	NAMEPLATE, BLANK, FOR VALVES WITH SPRINGS OR DETENTS
8	1	V-7	PIN, ROLL 3/16 X 11/16, STEEL, FOR 1/4 THRU 1/2" HAND, FT & CAM V
7	1	HL3-24	HAND LEVER WITH KNOB, 1/4" & 3/8" VALVE
6	1	HE3-1LO	END CAP, LEVER, LOCK OUT, 380 AL, 1/4" & 3/8" VALVE
5	1	AY-HA3LO	ASSY - LOCKOUT A, RTRN TO A, LEVER OR TREADLE, 1/4 & 3/8 VALVES
4	8	V-38	SCREW, 10-24 X 3/4, SOCKET HEAD CAP
3	2	ECG3	GASKET - END CAP, 1/4" & 3/8" VALVE
2	6	V-39	O-RING, VITON, STD BODY, 1/4" & 3/8" VALVES
1	1	BP3-2E	BODY - SOLID, PLAIN, NO PILOTS, ANODIZED, 3/8" SUBPLATE VALVE

LIMITS ON DIMENSIONS
UNLESS OTHERWISE SPECIFIED

2-PL DECIMAL ± .01
3-PL DECIMAL ± .005
FRACTIONAL ± 1/64
ANGULAR ± 1/2°



DRAWN: RMckenna DATE: 9/6/2016
SCALE: 1 : 1 SHEET: 1 OF 1

CHECKED: KWaite DATE: 9/6/2016
RELEASED: HWomack DATE: 9/6/2016

TITLE:
3/8" SUBPLATE, LEVER, 2 POS,
RVRS SPR RTRN, LOCKOUT A

PART NO.:
HA3PLO REV.:

