

POSITION GASKET ON END OF VALVE TO SEAL PILOT HOLE IF PRESENT, BOTH SIDES (SIDE 'B' SHOWN)

NOTES:

1) ALWAYS GIVE VALVE MODEL AND PART NUMBER WHEN ORDERING PARTS.

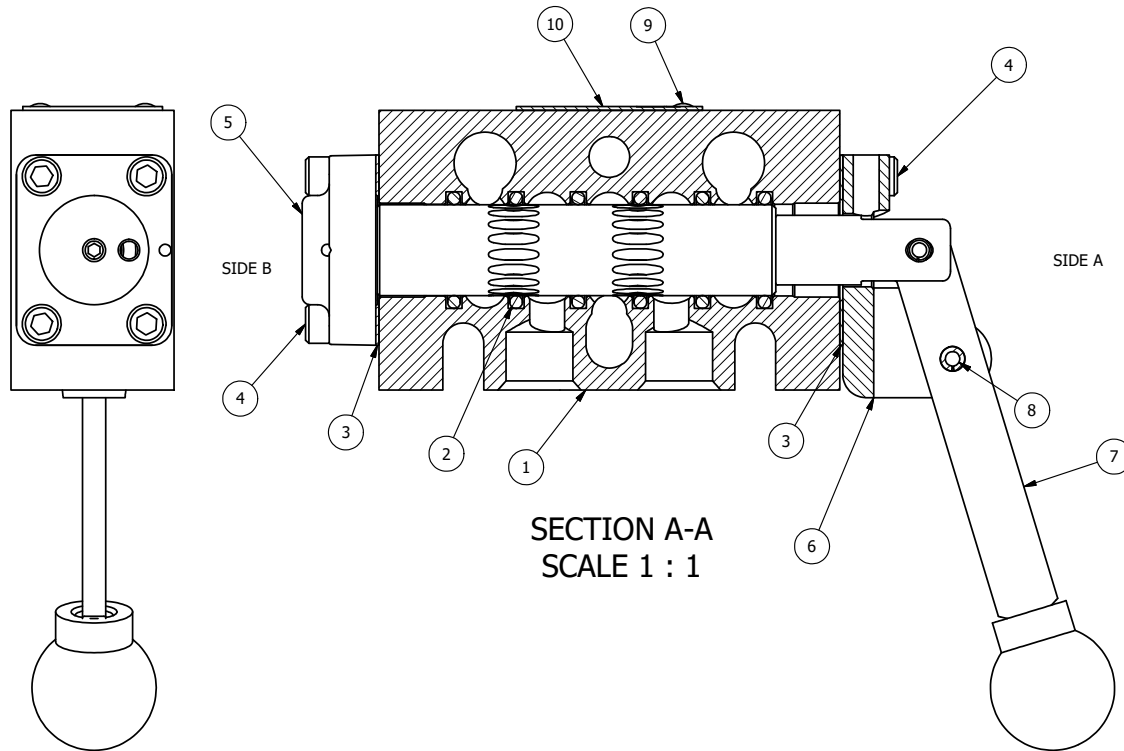

| FLG | QTY | PART NO | DESCRIPTION |
|-----|-----|---------|---|
| 11 | 3 | V-110 | O-RING, BUNA-N, 70 DURO, AS-114, (REF 5/8 X 13/16 X 3/32), 1/4" SLEEVE, 1/2" SUB, STACK |
| 10 | 1 | AN-114 | NAMEPLATE, BLANK, FOR VALVES WITH SPRINGS OR DETENTS |
| 9 | 2 | V-212 | SCREW, #2 X 3/16 DRIVE, TYPE U, OVAL HEAD, STAINLESS STEEL |
| 8 | 1 | V-542 | PIN, ROLL 3/16 X 1/2 ZINC PLATED STEEL FOR HE3-4 END CAP |
| 7 | 1 | HL3-24 | HAND LEVER WITH KNOB, 1/4" & 3/8" VALVE |
| 6 | 1 | HE3-4 | ENDCAP - HAND OPERATOR, 303 STAINLESS, 1/4" & 3/8" STACK VALVE |
| 5 | 1 | AY-HA3 | ASSY - NO DETENT, RTRN TO POS A, LEVER OR TREADLE, 1/4 & 3/8 VALVES |
| 4 | 8 | V-38 | SCREW, 10-24 X 3/4, SOCKET HEAD CAP |
| 3 | 2 | ECG3 | GASKET - END CAP, 1/4" & 3/8" VALVE |
| 2 | 6 | V-39 | O-RING, VITON, STD BODY, 1/4" & 3/8" VALVES |
| 1 | 1 | B3-10E | FINISHED - SOLID BODY, UPPER PILOTS, 3/8" STACKING VALVE |

| | | | | | |
|--|--|--|--|--|-------|
| LIMITS ON DIMENSIONS UNLESS OTHERWISE SPECIFIED | | 2-PL DECIMAL ± .01 3-PL DECIMAL ± .005 FRACTIONAL ± 1/64 ANGULAR ± 1/2° | | AAA PRODUCTS INTERNATIONAL 7114 Harry Hines Blvd Dallas, TX 75235 | |
| DRAWN: RMckenna | | DATE: 9/7/2016 | | | |
| SCALE: 1 : 1 | | SHEET: 1 OF 1 | | CHECKED: KWaite DATE: 9/7/2016 RELEASED: HWomack DATE: 9/7/2016 | |
| TITLE: 3/8" STACK, LEVER, 2 POS, RVRs SPR RTRN, 180D LEVER | | | | PART NO.: BHA3T | REV.: |

THE INFORMATION CONTAINED WITHIN THIS DOCUMENT IS PROPRIETARY TO AAA PRODUCTS AND MAY NOT BE DISCLOSED WITHOUT PRIOR WRITTEN CONSENT

P:\Engineering\product\Valves\Assembly\Levers\180D\BHA3T.dwg