

ALIGN PILOT AND HOLE IN GASKET BOTH SIDES (SIDE 'A' SHOWN)

NOTES:
1) ALWAYS GIVE VALVE MODEL AND PART NUMBER WHEN ORDERING PARTS.

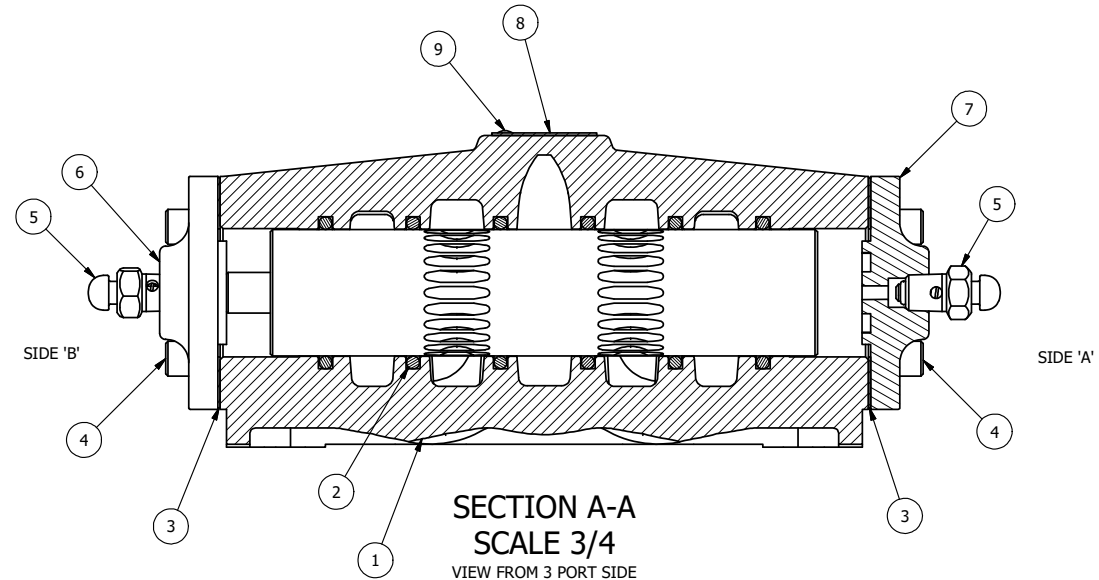

FLG	QTY	PART NO	DESCRIPTION
9	2	V-212	SCREW, 2 X 3/16, DRIVE, TYPE U, OVAL HEAD, 316 SS
8	1	AN-114	NAME PLATE, BLANK, FOR VALVES WITH SPRINGS OR DETENTS.
7	1	DP48	ENDCAP - DP48, DIFFERENTIAL PILOT, 380 AL, 1/2", 3/4" & 1" VALVES
6	1	AY-DY8	ASSY - SPR CTR, CLSD CTR SPL, DIFF PILOT, 3/4" & 1" VALVE
5	2	BB-1S	COMPLETE BUTTON BLEEDER ASSY W/STEEL PLUNGER
4	8	V-46	SCREW, 1/4-20 X 3/4, SOCKET HEAD CAP
3	2	ECG48-3	GASKET - END CAP, BUTTON BLEEDER, 1/2", 3/4" & 1" VALVE
2	6	V-30	O-RING, BUNA-N, 70 DURO, AS-220, (REF 1-3/8 X 1-5/8 X 1/8), 3/4" & 1" VALVES
1	1	B6-1	BODY, 3/4" SIDE PORT, UPPER PILOTS, ANODIZED

LIMITS ON DIMENSIONS
UNLESS OTHERWISE SPECIFIED

2-PL DECIMAL ± .01
3-PL DECIMAL ± .005
FRACTIONAL ± 1/64
ANGULAR ± 1/2°

AAA PRODUCTS INTERNATIONAL
7114 Harry Hines Blvd
Dallas, TX 75235

DRAWN: RHuffstetter	DATE: 8/1/2001	CHECKED: KWaitte	DATE: 3/27/2015
SCALE: 3/4	SHEET: 1 OF 1	RELEASED: HWomack	DATE: 3/27/2015
TITLE: 3/4" SIDE PORT, DIFF PILOT, 3 POS, SPR CTR, DIFF PILOT SHFT, CLSD CTR SPL		PART NO.: DY6	REV.: A

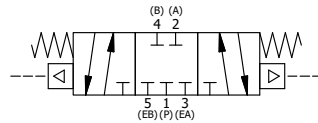

A	NO.	DATE	REVISION
3/13/2019	CHANGED GASKET TO ECG48-3.		

THE INFORMATION CONTAINED WITHIN THIS DOCUMENT IS PROPRIETARY TO AAA PRODUCTS AND MAY NOT BE DISCLOSED WITHOUT PRIOR WRITTEN CONSENT

D:\Engineering\Inventor Files\Internal Drawings\Valves Assembly\DiffPilot\DY6.dwg