

ALIGN PILOT HOLE AND GASKET HOLE BOTH SIDES (SIDE 'A' SHOWN)

NOTES:
1) ALWAYS GIVE VALVE MODEL AND PART NUMBER WHEN ORDERING PARTS.

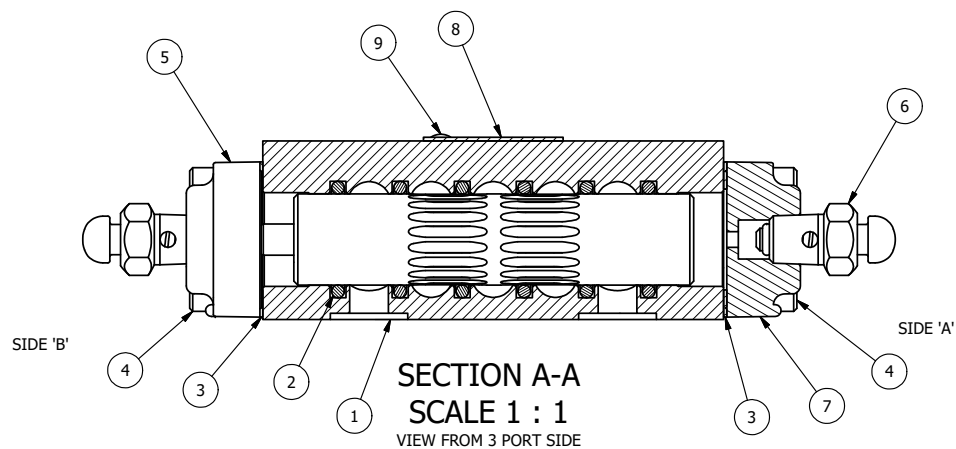

FLG	QTY	PART NO	DESCRIPTION
10	1	SPK-3	KIT - SUBPLATE MOUNTING, 3/8" SUBPLATE VALVES
9	2	V-212	SCREW, #2 X 3/16 DRIVE, TYPE U, OVAL HEAD, STAINLESS STEEL
8	1	AN-114	NAME PLATE, BLANK, FOR VALVES WITH SPRINGS OR DETENTS.
7	1	DP3	ENDCAP - DP3, 380 AL, 1/4" & 3/8" VALVE
6	2	BB-1S	COMPLETE BUTTON BLEEDER ASSY W/STEEL PLUNGER
5	1	AY-DY3D	ASSY - SPR CTR, REGEN CTR SPL, DIFF PILOT, 1/4 & 3/8 VALVES
4	8	V-38	SCREW, 10-24 X 3/4, SOCKET HEAD CAP
3	2	BG3	GASKET - END CAP, 1/4" & 3/8" VALVE
2	6	V-39	O-RING, VITON, STD BODY, 1/4" & 3/8" VALVES
1	1	BP3-1E	BODY - SOLID, BUTTON BLEEDER, ANODIZED, 3/8" SUBPLATE VALVE

LIMITS ON DIMENSIONS UNLESS OTHERWISE SPECIFIED		2-PL DECIMAL ± .01 3-PL DECIMAL ± .005 FRACTIONAL ± 1/64 ANGULAR ± 1/2°		AAA PRODUCTS INTERNATIONAL 7114 Harry Hines Blvd Dallas, TX 75235
DRAWN: RMckenna	DATE: 5/3/2010	CHECKED: KWaite	DATE: 3/27/2015	
SCALE: 1 : 1	SHEET: 1 OF 1	RELEASED: HWomack	DATE: 3/27/2015	
TITLE: 3/8" SUBPLATE, DIFF PILOT, 3 POS, SPR CTR, DIFF PILOT SHFT, REGEN CTR SPL			PART NO.: DY3PD	REV.:

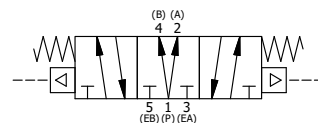

THE INFORMATION CONTAINED WITHIN THIS DOCUMENT IS PROPRIETARY TO AAA PRODUCTS AND MAY NOT BE DISCLOSED WITHOUT PRIOR WRITTEN CONSENT

D:\Engineering\product\Valve Assembly\Different\DY3PD\DY3PD.dwg