

POSITION GASKET ON END OF VALVE TO ALIGN PILOT HOLES, BOTH SIDES (SIDE 'B' SHOWN)

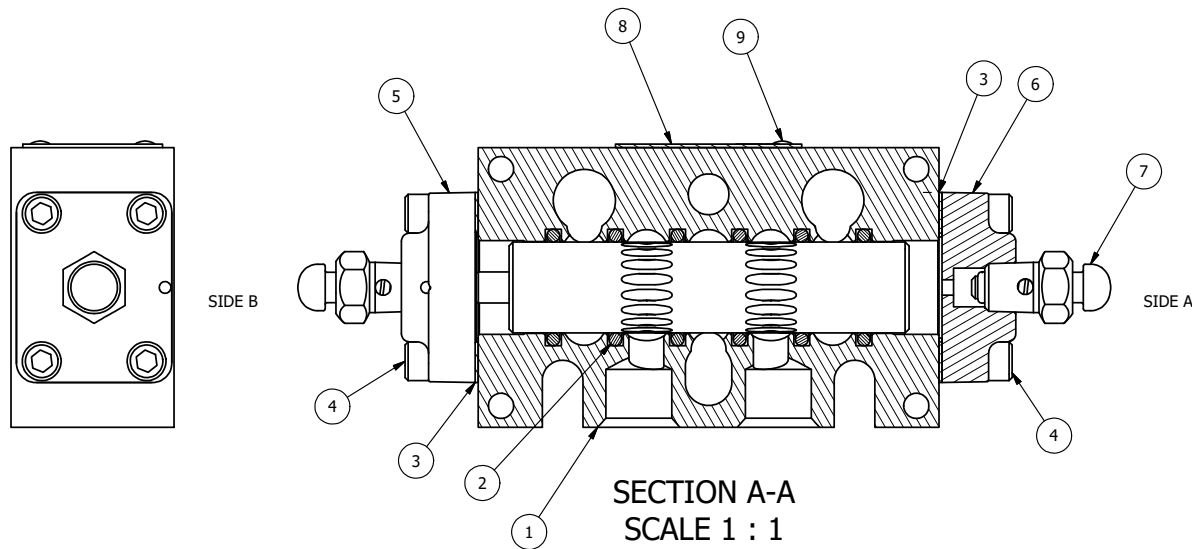

FLG	QTY	PART NO	DESCRIPTION
10	3	V-110	O-RING, BUNA-N, 70 DURO, AS-114, (REF 5/8 X 13/16 X 3/32), 1/4" SLEEVE, 1/2" SUB, STACK
9	2	V-212	SCREW, #2 X 3/16 DRIVE, TYPE U, OVAL HEAD, STAINLESS STEEL
8	1	AN-114	NAME PLATE, BLANK, FOR VALVES WITH SPRINGS OR DETENTS.
7	2	BB-1S	COMPLETE BUTTON BLEEDER ASSY W/STEEL PLUNGER
6	1	DP3	ENDCAP - DP3, 380 AL, 1/4" & 3/8" VALVE
5	1	AY-DY3	ASSY - SPR CTR, CLSD CTR SPL, DIFF PILOT, 1/4 & 3/8 VALVES
4	8	V-38	SCREW, 10-24 X 3/4, SOCKET HEAD CAP
3	2	BG3	GASKET - END CAP, 1/4" & 3/8" VALVE
2	6	V-39	O-RING, VITON, STD BODY, 1/4" & 3/8" VALVES
1	1	B3-10E	FINISHED - SOLID BODY, UPPER PILOTS, 3/8" STACKING VALVE

NOTES:
1) ALWAYS GIVE VALVE MODEL AND PART NUMBER WHEN ORDERING PARTS.

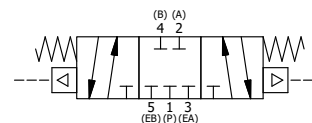

LIMITS ON DIMENSIONS UNLESS OTHERWISE SPECIFIED		2-PL DECIMAL ± .01 3-PL DECIMAL ± .005 FRACTIONAL ± 1/64 ANGULAR ± 1/2°		AAA PRODUCTS INTERNATIONAL 7114 Harry Hines Blvd Dallas, TX 75235
DRAWN: RMckenna	DATE: 10/16/2014	CHECKED: KWaite	DATE: 3/27/2015	
SCALE: 1:1	SHEET: 1 OF 1	RELEASED: HWomack	DATE: 3/27/2015	
TITLE: 3/8" STACK, DIFF PILOT, 3 POS SPR CTR, CLSD CTR SPOOL			PART NO.: BDY3	REV.:

THE INFORMATION CONTAINED WITHIN THIS DOCUMENT IS PROPRIETARY TO AAA PRODUCTS AND MAY NOT BE DISCLOSED WITHOUT PRIOR WRITTEN CONSENT

P:\Engineering\product\Valve Assembly\Diffrential\DWG\BDY3.dwg