

NOTES:
1) ALWAYS GIVE VALVE MODEL AND PART NUMBER WHEN ORDERING PARTS.

POSITION GASKET TO SEAL PILOT HOLE ON SIDE 'B' AS SHOWN.

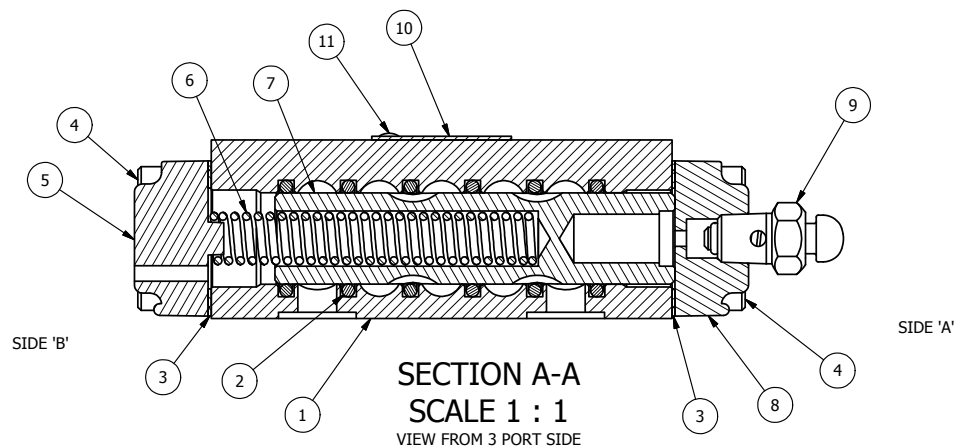

12	1	SPK-3	KIT - 3/8" SUBPLATE MOUNTING WITH SCREWS
11	2	V-212	SCREW, #2 X 3/16 DRIVE, TYPE U, OVAL HEAD, 316 STAINLESS STEEL
10	1	AN-114	NAME PLATE, BLANK, FOR VALVES WITH SPRINGS OR DETENTS.
9	1	BB-1S	COMPLETE BUTTON BLEEDER ASSY W/STEEL PLUNGER
8	1	DP3	ENDCAP - DP3, 380 AL, 1/4" & 3/8" VALVE
7	1	S3	SPOOL - STANDARD, 2 POS, CLSD CTR, 1/4" & 3/8" VALVE
6	1	SW6991	SPRING - RETURN, 80 PSI, 1/4" & 3/8" VALVES
5	1	SEC3-A	END CAP, VENTED, SPRING BOSS, 380 AL, 1/4" & 3/8" VALVE
4	8	V-38	SCREW, 10-24 X 3/4 SHCS, FOR 3/8" CAST END CAP
3	2	BG3	GASKET - END CAP, 1/4" & 3/8" VALVE
2	6	V-39	O-RING, STD BODY, VITON, 1/4" & 3/8" VALVES
1	1	BP3-1E	BODY - SOLID, BUTTON BLEEDER, ANODIZED, 3/8" SUBPLATE VALVE
FLG	QTY	PART NO	DESCRIPTION

LIMITS ON DIMENSIONS
UNLESS
OTHERWISE SPECIFIED

2-PL DECIMAL ± .01
3-PL DECIMAL ± .005
FRACTIONAL ± 1/64
ANGULAR ± 1/2°



DRAWN: RMckenna DATE: 10/11/2010

CHECKED: KWaite DATE: 3/27/2015

SCALE: 1 : 1 SHEET: 1 OF 1

RELEASED: HWomack DATE: 3/27/2015

TITLE:
**3/8" SUBPLATE, DIFF PILOT, 2 POS,
SPRING RTRN**

PART NO.:
DO3P

REV.:
D

NO.	DATE	REVISION
D	10/18/2014	CHANGED GASKET BACK TO BG3
C	3/17/06	CHANGED GASKET FROM BG3 TO ECG3
B	2/7/06	CORRECT SPR FROM CS3 TO SW6991
A	7/20/05	CHANGED GASKET FROM NEG3 TO BG3

