

ALIGN HOLES IN GASKET AS SHOWN.
 (FOR EXTERNAL PILOT PRESSURE, REMOVE PIGGY BACK
 BLOCK AND ROTATE 180°. LEAVE GASKET AS SHOWN. REMOVE
 1/8" PLUG AND CONNECT SUPPLY PRESSURE - 160 PSI MAX.)

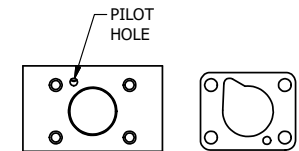

ALIGN PILOT HOLE AND CENTER CUTOUT
 ON BOTH SIDES.

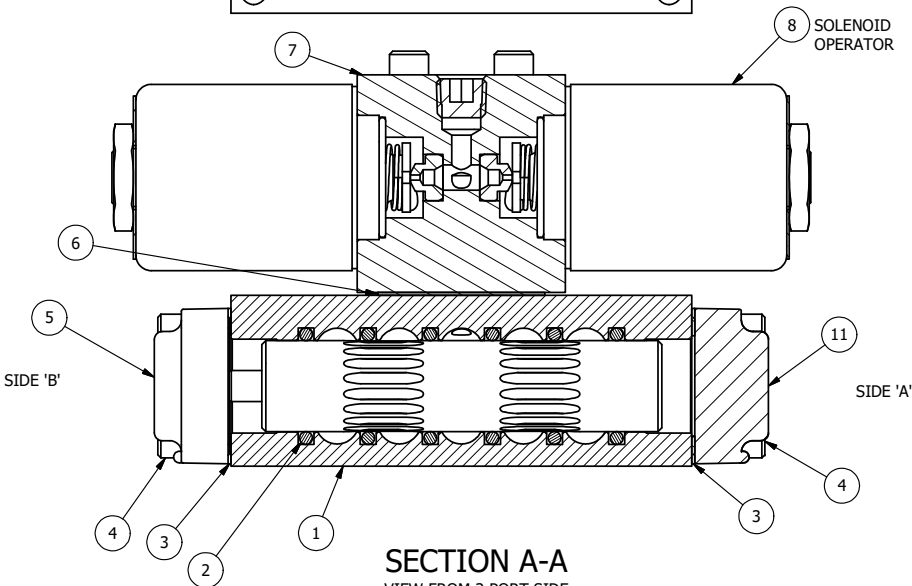

SECTION A-A
 VIEW FROM 3 PORT SIDE

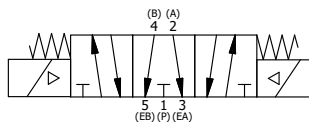

NOTES:

- 1) ALWAYS GIVE VALVE MODEL AND PART NUMBER WHEN ORDERING PARTS.
- 2) FOR DIFFERENT VOLTAGES OTHER THAN 120/60, REPLACE SOLENOID OPERATOR WITH OPERATOR LISTED IN TABLE BELOW. REFERENCE AY-38 DRAWING FOR REPLACEMENT COILS.

FLG	QTY	PART NO	DESCRIPTION
13	2	V-212	SCREW, #2 X 3/16 DRIVE, TYPE U, OVAL HEAD, STAINLESS STEEL
12	1	AN-114	NAMEPLATE, BLANK, FOR VALVES WITH SPRINGS OR DETENTS
11	1	SEC3-1	END CAP, NON-VENTED, 3/8 AL, 1/4" & 3/8" VALVES
10	1	V-19	PLUG, SOCKET PIPE 1/8" NPT (#601-3 PITTSBURG PLUG PART #.)
9	4	V-1	SCREW, 10-24 X 2, SOCKET HEAD CAP
8	2	AY-38-11	CLASSIC SOLENOID - STANDARD, COMPLETE OPERATOR, 120/60
7	1	PB3-2E	ADAPTOR - DOUBLE SOLENOID, 1/4" & 3/8" VALVES
6	1	PBG3	GASKET - PIGGY BACK, DOUBLE SOLENOID, 1/4" & 3/8" VALVE
5	1	AY-EY3G	SPRING CENTER SPOOL ASSY, CLASSIC SOLENOID, G SPOOL, 1/4 & 3/8 VALVES
4	8	V-38	SCREW, 10-24 X 3/4, SOCKET HEAD CAP
3	2	ECG3	GASKET - END CAP, 1/4" & 3/8" VALVE
2	6	V-39	O-RING, VITON, STD BODY, 1/4" & 3/8" VALVES
1	1	B2-6E	BODY - SOLID, PIGGY BACK, ANODIZED, 1/4" SIDE PORT VALVE

LIMITS ON DIMENSIONS UNLESS OTHERWISE SPECIFIED		2-PL DECIMAL ± .01 3-PL DECIMAL ± .005 FRACTIONAL ± 1/64 ANGULAR ± 1/2°		AAA PRODUCTS INTERNATIONAL 7114 Harry Hines Blvd Dallas, TX 75235									
DRAWN: RMckenna		DATE: 11/7/2014		CHECKED: KWaite									
SCALE: 1 : 1		SHEET: 1 OF 1		DATE: 5/30/2015									
OPERATOR VOLTAGES		TITLE:		PART NO.:									
<table border="1"> <thead> <tr> <th>PART NO</th> <th>REPLACE OPERATOR</th> </tr> </thead> <tbody> <tr> <td>SY2G 240/60</td> <td>AY-38-17</td> </tr> <tr> <td>SY2G 24VDC</td> <td>AY-38-8</td> </tr> <tr> <td>SY2G 12VDC</td> <td>AY-38-5</td> </tr> </tbody> </table>		PART NO	REPLACE OPERATOR	SY2G 240/60	AY-38-17	SY2G 24VDC	AY-38-8	SY2G 12VDC	AY-38-5	1/4" SIDE PORT, DBL SOL, 3 POS, SPR CTR, SOL SHFT, FLOAT CTR SPL, CLASSIC SOL, 120/60		SY2G	
PART NO	REPLACE OPERATOR												
SY2G 240/60	AY-38-17												
SY2G 24VDC	AY-38-8												
SY2G 12VDC	AY-38-5												

THE INFORMATION CONTAINED WITHIN THIS DOCUMENT IS PROPRIETARY TO AAA PRODUCTS AND MAY NOT BE DISCLOSED WITHOUT PRIOR WRITTEN CONSENT

P:\Engineering\product\Valve Assembly\Classic\SY2G\SY2G.dwg