

ALIGN HOLES IN GASKET AS SHOWN.  
 (FOR EXTERNAL PILOT PRESSURE, REMOVE PIGGY BACK BLOCK AND ROTATE 180°. LEAVE GASKET AS SHOWN. REMOVE 1/8" PLUG AND CONNECT SUPPLY PRESSURE - 160 PSI MAX.)

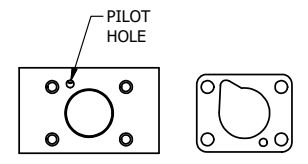

ALIGN PILOT HOLE AND CENTER CUTOUT ON BOTH SIDES.

NOTES:  
 1) ALWAYS GIVE VALVE MODEL AND PART NUMBER WHEN ORDERING PARTS.  
 2) FOR DIFFERENT VOLTAGES OTHER THAN 120/60, REPLACE SOLENOID OPERATOR WITH OPERATOR LISTED IN TABLE BELOW. REFERENCE AY-38M DRAWING FOR REPLACEMENT COILS.

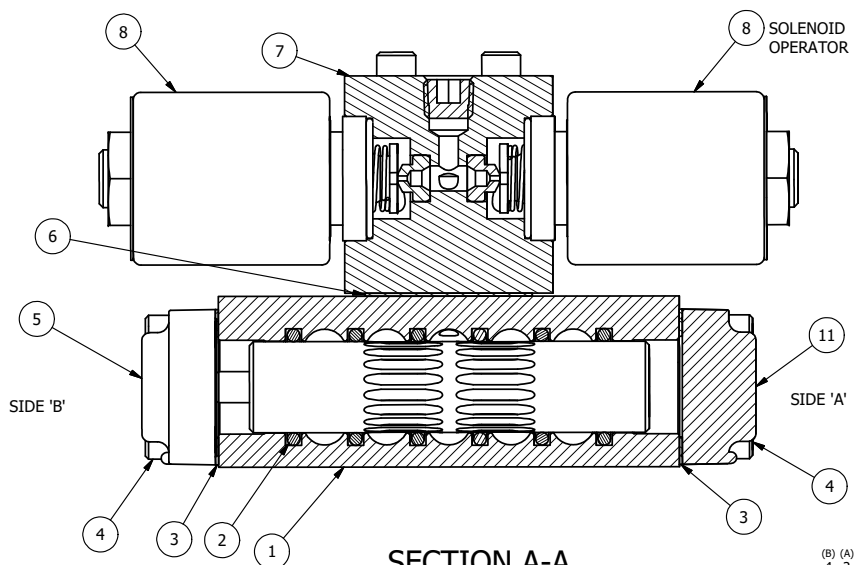

SECTION A-A  
 VIEW FROM 3 PORT SIDE

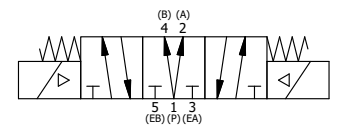

FLG	QTY	PART NO	DESCRIPTION
13	2	V-212	SCREW, #2 X 3/16 DRIVE, TYPE U, OVAL HEAD, STAINLESS STEEL
12	1	AN-114	NAMEPLATE, BLANK, FOR VALVES WITH SPRINGS OR DETENTS
11	1	SEC3-1	END CAP, NON-VENTED, 3/8 AL, 1/4" & 3/8" VALVES
10	1	V-19	PLUG, SOCKET PIPE 1/8" NPT (#601-3 PITTSBURG PLUG PART #.)
9	4	V-1	SCREW, 10-24 X 2, SOCKET HEAD CAP
8	2	AY-38M-11	CLASSIC SOLENOID - 1/2" NPT CONDUIT, 120/60
7	1	PB3-2E	ADAPTOR - DOUBLE SOLENOID, 1/4" & 3/8" VALVES
6	1	PBG3	GASKET - PIGGY BACK, DOUBLE SOLENOID, 1/4" & 3/8" VALVE
5	1	AY-EY3D	ASSY - SPR CTR, REGEN CTR SPL, CLASSIC SOLENOID, 1/4 & 3/8 VALVES
4	8	V-38	SCREW, 10-24 X 3/4, SOCKET HEAD CAP
3	2	ECG3	GASKET - END CAP, 1/4" & 3/8" VALVE
2	6	V-39	O-RING, VITON, STD BODY, 1/4" & 3/8" VALVES
1	1	B2-6E	BODY - SOLID, PIGGY BACK, ANODIZED, 1/4" SIDE PORT VALVE

LIMITS ON DIMENSIONS  
 UNLESS OTHERWISE SPECIFIED  
 2-PL DECIMAL ± .01  
 3-PL DECIMAL ± .005  
 FRACTIONAL ± 1/64  
 ANGULAR ± 1/2°



DRAWN: RMckenna DATE: 5/6/2015 CHECKED: KWaite DATE: 5/30/2015  
 SCALE: 1 : 1 SHEET: 1 OF 1 RELEASED: HWomack DATE: 5/30/2015

OPERATOR VOLTAGES	
PART NO	REPLACE OPERATOR
SY2DM 240/60	AY-38M-17
SY2DM 24VDC	AY-38M-8
SY2DM 12VDC	AY-38M-5

TITLE:  
 1/4" SIDE PORT, DBL SOL, 3 POS,  
 SPR CTR, SOL SHFT, REGEN CTR SPL,  
 MOLD-OVER, 120/60

PART NO.:	SY2DM	REV.:	
-----------	-------	-------	--

THE INFORMATION CONTAINED WITHIN THIS DOCUMENT IS PROPRIETARY TO AAA PRODUCTS AND MAY NOT BE DISCLOSED WITHOUT PRIOR WRITTEN CONSENT

P:\Engineering\product\Valve Assembly\Classic\SY2DM\SY2DM.dwg