

ALIGN PILOT AND HOLE IN GASKET, BOTH SIDES.
 FOR EXTERNAL PILOT OPERATION - ROTATE THE
 ROUND ALUMINUM ADAPTOR 90 OR 180 DEGREES.
 REMOVE 1/8" NPTF PLUG AND SUPPLY 50-300 PSI TO
 1/8" NPTF PILOT PORT IN ADAPTOR.

- NOTES:
- 1) ALWAYS GIVE VALVE MODEL AND PART NUMBER WHEN ORDERING PARTS.
 - 2) FOR DIFFERENT VOLTAGES OTHER THAN 120/60, REPLACE SOLENOID OPERATOR WITH OPERATOR LISTED IN TABLE BELOW. REFERENCE AY-38V DRAWING FOR REPLACEMENT COILS.
 - 3) MARK NAMETAG AND SOLENOID TAG 300 PSI MAX.
 - 4) STANDARD TESTING THEN TEST AT 300 PSI.

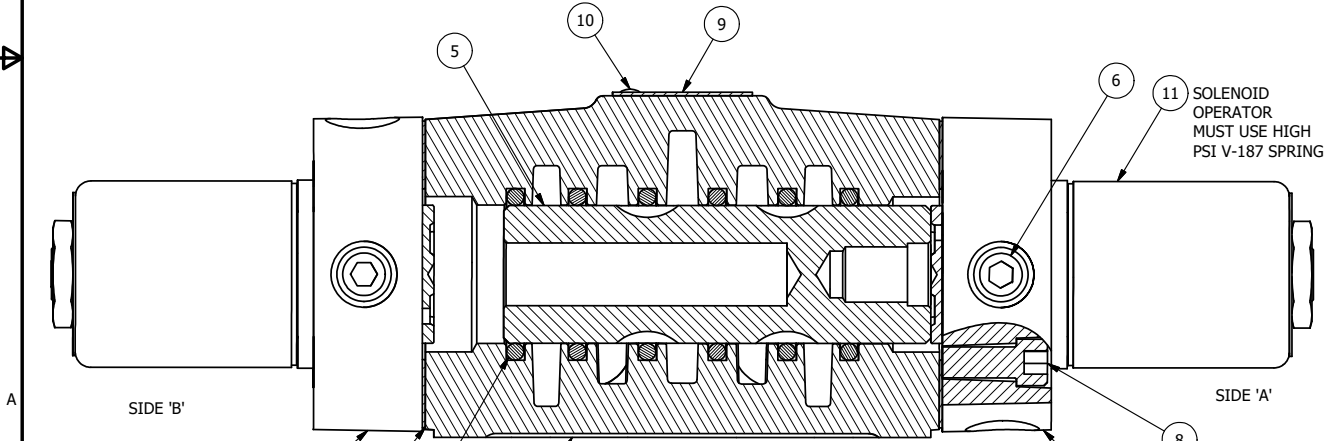

FLG	QTY	PART NO	DESCRIPTION
11	2	AY-38V	CLASSIC SOLENOID - HIGH PRESSURE, COMPLETE OPERATOR, 120/60
10	2	V-212	SCREW, #2 X 3/16 DRIVE, TYPE U, OVAL HEAD, STAINLESS STEEL
9	1	AN-115	NAMEPLATE, BLANK, FOR HE,KE,RR,D,CR,PP,SR,SS VALVES
8	8	V-47	SCREW, 1/4-20 X 1, SOCKET HEAD CAP
6	2	V-19	PLUG, SOCKET PIPE 1/8" NPT, 7/8 TAPER, FLUSH SEAL
5	1	S4	SPOOL - STANDARD, 2 POS, CLSD CTR, 1/2" VALVE
4	2	SS48-V	ADAPTOR, SOLENOID, 250 PSI, 1/2", 3/4" & 1" VALVE
3	2	ECG48-3	GASKET - END CAP, BUTTON BLEEDER, 1/2", 3/4" & 1" VALVE
2	6	V-6	O-RING, BUNA-N, 70 DURO, AS-216, (REF 1-1/8 X 1-3/8 X 1/8), 1/2" VALVES, 1" SUBPLATE
1	1	B4-1	BODY, 1/2" SIDE PORT, UPPER PILOTS, ANODIZED

LIMITS ON DIMENSIONS
 UNLESS OTHERWISE SPECIFIED
 2-PL DECIMAL ± .01
 3-PL DECIMAL ± .005
 FRACTIONAL ± 1/64
 ANGULAR ± 1/2°



DRAWN: RMckenna DATE: 5/18/2016 CHECKED: KWaite DATE: 5/18/2016
 SCALE: 1 : 1 SHEET: 1 OF 1 RELEASED: HWomack DATE: 5/18/2016

OPERATOR VOLTAGES	
PART NO	REPLACE OPERATOR
SS4V 240/60	AY-38V-17
SS4V 24VDC	AY-38V-8
SS4V 12VDC	AY-38V-5

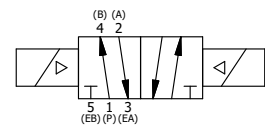

TITLE:
**1/2" SIDE PORT, DBL SOL, 2 POS,
 FRICTION POS, SOL RTRN, 300 PSI,
 CLASSIC SOL, 120/60**

PART NO.: **SS4V** REV.: **A**

A	NO.	DATE	CHNGD GSKT FRM ECG48 TO ECG48-3	REVISION
		6/21/2023		

THE INFORMATION CONTAINED WITHIN THIS DOCUMENT IS PROPRIETARY TO AAA PRODUCTS AND MAY NOT BE DISCLOSED WITHOUT PRIOR WRITTEN CONSENT