

NOTES:
 1) ALWAYS GIVE VALVE MODEL AND PART NUMBER WHEN ORDERING PARTS.
 2) FOR DIFFERENT VOLTAGES OTHER THAN 120/60, REPLACE SOLENOID OPERATOR WITH OPERATOR LISTED IN TABLE BELOW. REFERENCE AY-38T DRAWING FOR REPLACEMENT COILS.

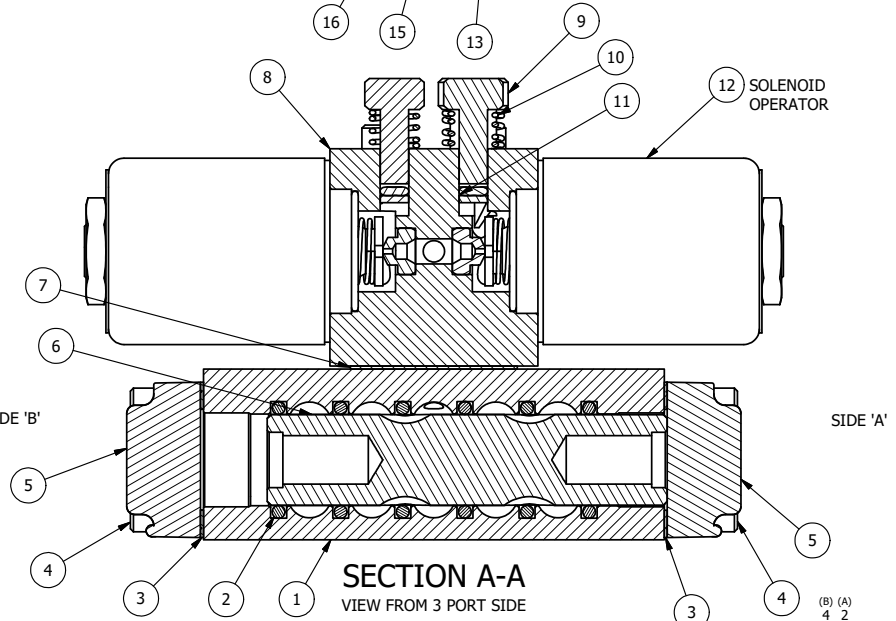

16	2	V-212	SCREW, #2 X 3/16 DRIVE, TYPE U, OVAL HEAD, STAINLESS STEEL
15	1	AN-115	NAMEPLATE, BLANK, FOR HE,KE,KD,RR,D,CR,PP,SR,SS VALVES
14	2	V-81	SCREW, 8-32 X 5/16, SOCKET SET, FULL DOG POINT
13	4	V-1	SCREW, 10-24 X 2, SOCKET HEAD CAP
12	2	AY-38T-11	CLASSIC SOLENOID - STANDARD, COMPLETE OPER, TAPPED EXH., 120/60
11	2	V-85	O-RING, BUNA-N, 70 DURO, AS-010, (REF 1/4 X 3/8 X 1/16), CLASSIC OVRD
10	2	OS3	SPRING - MANUAL OVERRIDE, "CLASSIC" SOLENOID
9	2	POP-3	OVERRIDE, PUSH PIN, 303 STAINLESS, 1/4" & 3/8" VALVE
8	1	PB3-4E	ADAPTOR - DBL SOL., W/OVERRIDE, 1/4" & 3/8" VALVES
7	1	PBG3	GASKET - PIGGY BACK, DOUBLE SOLENOID, 1/4" & 3/8" VALVE
6	1	S3R	SPOOL - SOLID, STANDARD, 2 POS, CLSD CTR, 1/4" & 3/8" VALVE
5	2	SEC3-1	END CAP, NON-VENTED, 380 AL, 1/4" & 3/8" VALVES
4	8	V-38	SCREW, 10-24 X 3/4, SOCKET HEAD CAP
3	2	ECG3	GASKET - END CAP, 1/4" & 3/8" VALVE
2	6	V-39	O-RING, VITON, STD BODY, 1/4" & 3/8" VALVES
1	1	B3-6E	BODY - SOLID, PIGGY BACK, ANODIZED, 3/8" SIDE PORT VALVE
FLG	QTY	PART NO	DESCRIPTION

LIMITS ON DIMENSIONS UNLESS OTHERWISE SPECIFIED	2-PL DECIMAL ± .01	AAA PRODUCTS INTERNATIONAL 7114 Harry Hines Blvd Dallas, TX 75235	
	3-PL DECIMAL ± .005		
	FRACTIONAL ± 1/64		
	ANGULAR ± 1/2°		
DRAWN: RMckenna	DATE: 2/6/2020	CHECKED: KWaite	DATE: 2/6/2020
SCALE: 1 : 1	SHEET: 1 OF 1	RELEASED: HWomack	DATE: 2/6/2020
TITLE: 3/8" SIDE PORT, DBL SOL, 2 POS, SOL RTRN, CLASSIC SOL, PUSH OVRD, TPD VENT, EXT PILOT		PART NO.:	REV.:
		SS3OPTZ	

OPERATOR VOLTAGES	
PART NO	REPLACE OPERATOR
SS3OPTZ 12VDC	AY-38T-5
SS3OPTZ 24VDC	AY-38T-8
SS3OPTZ 240/60	AY-38T-17

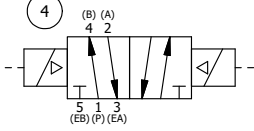

THE INFORMATION CONTAINED WITHIN THIS DOCUMENT IS PROPRIETARY TO AAA PRODUCTS AND MAY NOT BE DISCLOSED WITHOUT PRIOR WRITTEN CONSENT

D:\Engineering\product\Valve Assembly\Classic\SS3OPTZ.dwg