

ALIGN HOLES IN GASKET AS SHOWN.  
(PIGGY BACKBLOCK IS ROTATED 180°. CONNECT SUPPLY PRESSURE - 160 PSI MAX.)

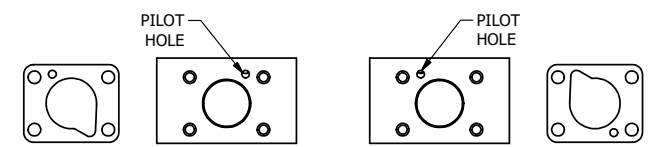

POSITION GASKET TO SEAL PILOT HOLE ON SIDE 'B' AS SHOWN. ALIGN PILOT HOLE AND CENTER CUTOUT ON SIDE 'A' AS SHOWN.

NOTES:  
1) ALWAYS GIVE VALVE MODEL AND PART NUMBER WHEN ORDERING PARTS.  
2) FOR DIFFERENT VOLTAGES OTHER THAN 120/60, REPLACE SOLENOID OPERATOR WITH OPERATOR LISTED IN TABLE BELOW. REFERENCE AY-38 DRAWING FOR REPLACEMENT COILS.

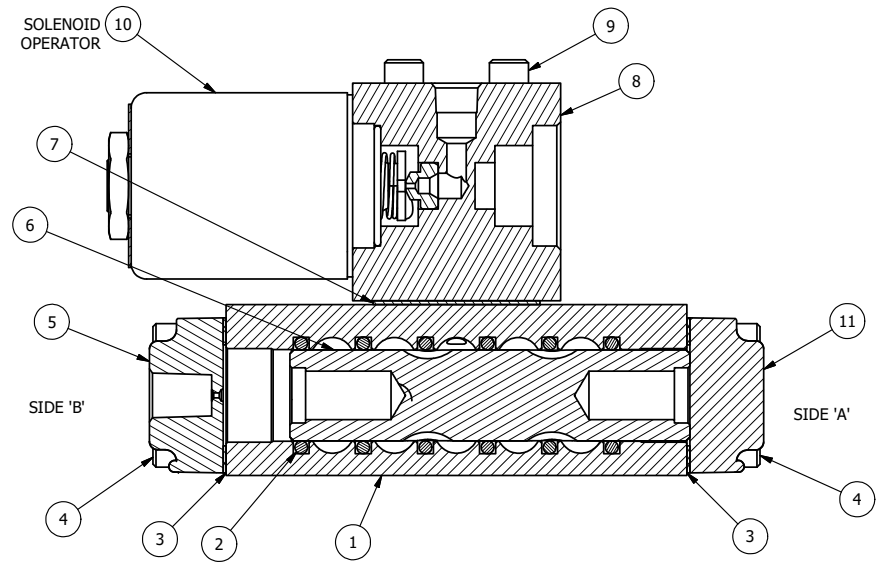

SECTION A-A  
VIEW FROM 3 PORT SIDE

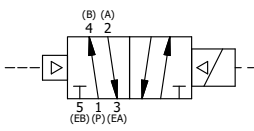

OPERATOR VOLTAGES	
PART NO	REPLACE OPERATOR
SRZZ 12VDC	AY-38-5
SRZZ 24VDC	AY-38-8
SRZZ 240/60	AY-38-17

FLG	QTY	PART NO	DESCRIPTION
13	2	V-212	SCREW, #2 X 3/16 DRIVE, TYPE U, OVAL HEAD, STAINLESS STEEL
12	1	AN-115	NAMEPLATE, BLANK, FOR HE,KE,KD,RR,D,CR,PP,SR,SS VALVES
11	1	SEC3-1	END CAP, NON-VENTED, 380 AL, 1/4" & 3/8" VALVES
10	1	AY-38-11	CLASSIC SOLENOID - STANDARD, COMPLETE OPERATOR, 120/60
9	4	V-1	SCREW, 10-24 X 2, SOCKET HEAD CAP
8	1	PB3-1E	ADAPTOR - SINGLE SOLENOID, 1/4" & 3/8" VALVES
7	1	PBG3-1	GASKET - PIGGY BACK, SINGLE SOLENOID, 1/4" & 3/8" VALVE
6	1	S3R	SPOOL - SOLID, STANDARD, 2 POS, CLSD CTR, 1/4" & 3/8" VALVE
5	1	PEC3	END CAP, PILOT, 380 AL, 1/4" & 3/8" VALVE
4	8	V-38	SCREW, 10-24 X 3/4, SOCKET HEAD CAP
3	2	ECG3	GASKET - END CAP, 1/4" & 3/8" VALVE
2	6	V-39	O-RING, VITON, STD BODY, 1/4" & 3/8" VALVES
1	1	B2-6E	BODY - SOLID, PIGGY BACK, ANODIZED, 1/4" SIDE PORT VALVE

LIMITS ON DIMENSIONS  
UNLESS OTHERWISE SPECIFIED  
2-PL DECIMAL ± .01  
3-PL DECIMAL ± .005  
FRACTIONAL ± 1/64  
ANGULAR ± 1/2°

**AAA PRODUCTS INTERNATIONAL**  
7114 Harry Hines Blvd  
Dallas, TX 75235

DRAWN: RMckenna DATE: 7/23/2015 CHECKED: KWaite DATE: 7/23/2015  
SCALE: 1 : 1 SHEET: 1 OF 1 RELEASED: HWomack DATE: 7/23/2015

TITLE: <b>1/4" SIDE PORT, SNGL SOL, 2 POS, FRICTION POS, PILOT RTRN, CLASSIC SOL, 120/60, EXT PILOT</b>	PART NO.: <b>SRZZ</b>	REV.:
------------------------------------------------------------------------------------------------------------	--------------------------	-------

THE INFORMATION CONTAINED WITHIN THIS DOCUMENT IS PROPRIETARY TO AAA PRODUCTS AND MAY NOT BE DISCLOSED WITHOUT PRIOR WRITTEN CONSENT

D:\Engineering\product\Valve Assembly\Classic\SRC\SRZZ.dwg