

4 | 1 | 3 | 2 | 1

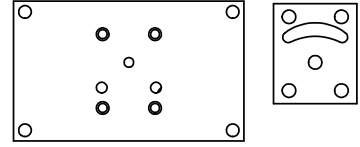

ALIGN HOLES IN GASKET AS SHOWN.  
(PIGGY BACKBLOCK IS ROTATED 180°. CONNECT SUPPLY PRESSURE - 160 PSI MAX.)

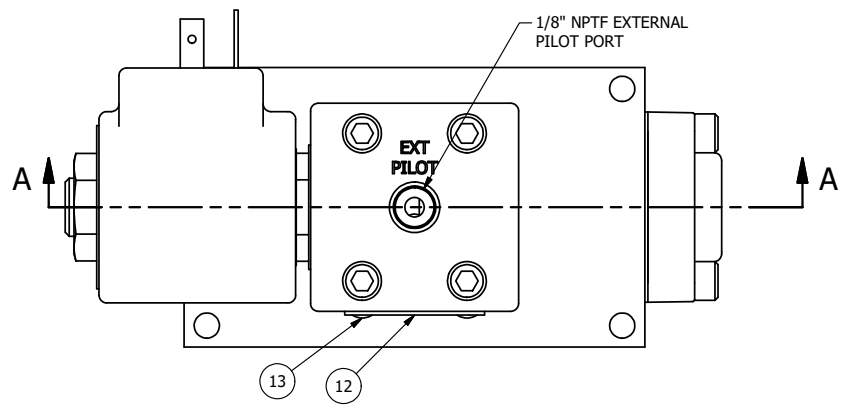
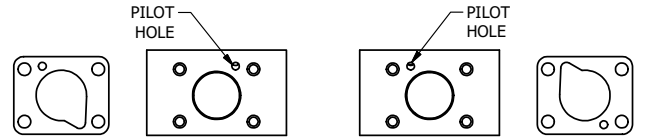

POSITION GASKET TO SEAL PILOT HOLE ON SIDE 'B' AS SHOWN. ALIGN PILOT HOLE AND CENTER CUTOUT ON SIDE 'A' AS SHOWN.

NOTES:  
1) ALWAYS GIVE VALVE MODEL AND PART NUMBER WHEN ORDERING PARTS.  
2) FOR DIFFERENT VOLTAGES OTHER THAN 120/60, REPLACE SOLENOID OPERATOR WITH OPERATOR LISTED IN TABLE BELOW. REFERENCE AY-38ED DRAWING FOR REPLACEMENT COILS.

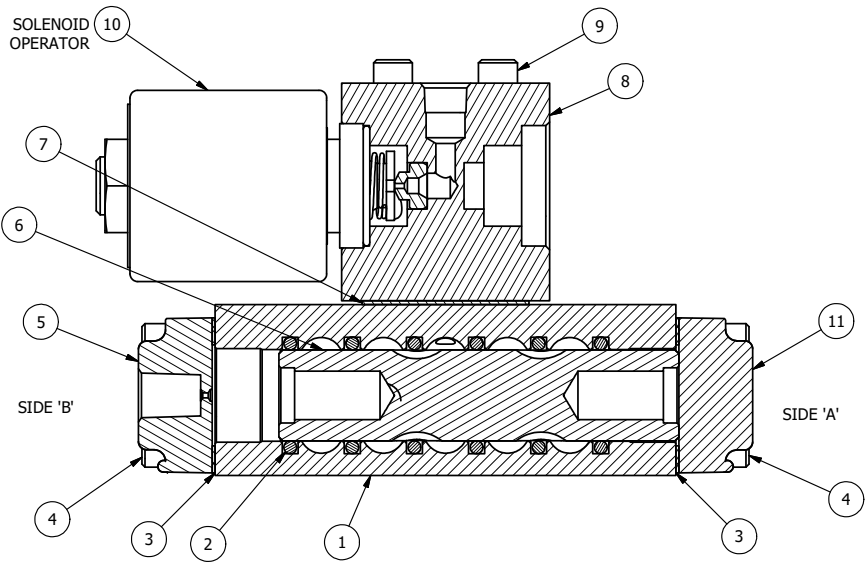

SECTION A-A  
VIEW FROM 3 PORT SIDE

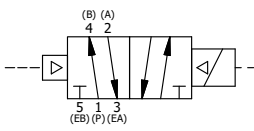

FLG	QTY	PART NO	DESCRIPTION
13	2	V-212	SCREW, #2 X 3/16 DRIVE, TYPE U, OVAL HEAD, STAINLESS STEEL
12	1	AN-115	NAMEPLATE, BLANK, FOR HE,KE,KD,RR,D,CR,PP,SR,SS VALVES
11	1	SEC3-1	END CAP, NON-VENTED, 380 AL, 1/4" & 3/8" VALVES
10	1	AY-38ED-11	CLASSIC SOLENOID - ISO 4400 DIN, 120/60
9	4	V-1	SCREW, 10-24 X 2, SOCKET HEAD CAP
8	1	PB3-1E	ADAPTOR - SINGLE SOLENOID, 1/4" & 3/8" VALVES
7	1	PBG3-1	GASKET - PIGGY BACK, SINGLE SOLENOID, 1/4" & 3/8" VALVE
6	1	S3R	SPOOL - SOLID, STANDARD, 2 POS, CLSD CTR, 1/4" & 3/8" VALVE
5	1	PEC3	END CAP, PILOT, 380 AL, 1/4" & 3/8" VALVE
4	8	V-38	SCREW, 10-24 X 3/4, SOCKET HEAD CAP
3	2	ECG3	GASKET - END CAP, 1/4" & 3/8" VALVE
2	6	V-39	O-RING, VITON, STD BODY, 1/4" & 3/8" VALVES
1	1	B2-6E	BODY - SOLID, PIGGY BACK, ANODIZED, 1/4" SIDE PORT VALVE

LIMITS ON DIMENSIONS  
UNLESS OTHERWISE SPECIFIED  
2-PL DECIMAL ± .01  
3-PL DECIMAL ± .005  
FRACTIONAL ± 1/64  
ANGULAR ± 1/2°

**AAA PRODUCTS INTERNATIONAL**  
7114 Harry Hines Blvd  
Dallas, TX 75235

DRAWN: RMckenna DATE: 2/16/2016 CHECKED: KWaite DATE: 2/16/2016  
SCALE: 1 : 1 SHEET: 1 OF 1 RELEASED: HWomack DATE: 2/16/2016

OPERATOR VOLTAGES	
PART NO	REPLACE OPERATOR
SR2EDZ 240/60	AY-38ED-17
SR2EDZ 24VDC	AY-38ED-8
SR2EDZ 12VDC	AY-38ED-5

TITLE:  
**1/4" SIDE PORT, SNGL SOL, 2 POS, FRICTION POS, PILOT RTRN, ISO 4400 DIN, 120/60, EXT PILOT**

PART NO.: **SR2EDZ**

REV.:

4 | 1 | 3 | 2 | 1

THE INFORMATION CONTAINED WITHIN THIS DOCUMENT IS PROPRIETARY TO AAA PRODUCTS AND MAY NOT BE DISCLOSED WITHOUT PRIOR WRITTEN CONSENT