

POSITION GASKET ON END OF VALVE SO
MOUNTING HOLES ALIGN,
BOTH ENDS (SIDE 'A' SHOWN)

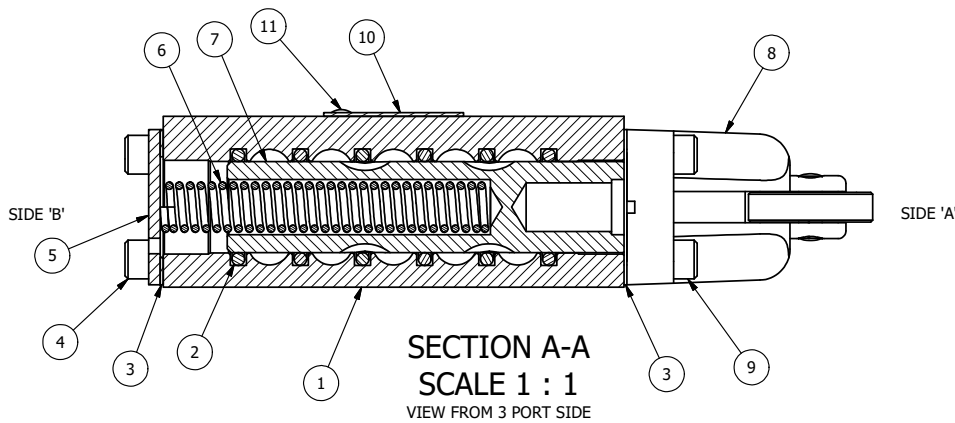

NOTES:

- 1) ALWAYS GIVE VALVE MODEL AND PART NUMBER WHEN ORDERING PARTS.
- 2) SEE AY-C3R ASSEMBLY PRINT FOR CAM OPERATOR PARTS DETAIL.

11	2	V-212	SCREW, #2 X 3/16 DRIVE, TYPE U, OVAL HEAD, STAINLESS STEEL
10	1	AN-114	NAME PLATE, BLANK, FOR VALVES WITH SPRINGS OR DETENTS.
9	4	V-38	SCREW, 10-24 X 3/4, SOCKET HEAD CAP
8	1	AY-C3R	CAM OPERATOR ASSEMBLY, ROTATED, 1/4" & 3/8" VALVES
7	1	S3	SPOOL - STANDARD, 2 POS, CLSD CTR, 1/4" & 3/8" VALVE
6	1	CS3	SPRING - RETURN, (EXCEPT HO, KO & PO) 1/4" & 3/8" VALVES
5	1	SEC3	END CAP, 304 STAINLESS STEEL, 1/4" & 3/8" VALVE
4	4	V-37	SCREW, 10-24 X 1/2, SOCKET HEAD CAP
3	2	ECG3	GASKET - END CAP, 1/4" & 3/8" VALVE
2	6	V-39	O-RING, VITON, STD BODY, 1/4" & 3/8" VALVES
1	1	B3-2E	BODY - SOLID, PLAIN, NO PILOTS, ANODIZED, 3/8" SIDE PORT VALVE
FLG	QTY	PART NO	DESCRIPTION

LIMITS ON DIMENSIONS UNLESS OTHERWISE SPECIFIED		2-PL DECIMAL ± .01 3-PL DECIMAL ± .005 FRACTIONAL ± 1/64 ANGULAR ± 1/2°		<p>AAA PRODUCTS INTERNATIONAL 7114 Harry Hines Blvd Dallas, TX 75235</p>	
DRAWN: RMckenna		DATE: 9/25/2014			CHECKED: KWaitte
SCALE: 1 : 1		SHEET: 1 OF 1		RELEASED: HWomack	DATE: 3/25/2015
TITLE: 3/8" SIDE PORT, CAM, 2 POS, SPRING RTRN, CAM ROTATED 90D				PART NO.: CO3R	REV.:

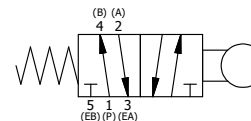

THE INFORMATION CONTAINED WITHIN THIS DOCUMENT IS PROPRIETARY TO AAA PRODUCTS AND MAY NOT BE DISCLOSED WITHOUT PRIOR WRITTEN CONSENT

P:\Engineering\Product\Valve Assembly\CAD\3D\303R.dwg