

PILOT HOLE  
POSITION GASKET ON END OF VALVE TO SEAL PILOT HOLE IF PRESENT, BOTH SIDES (SIDE 'B' SHOWN)

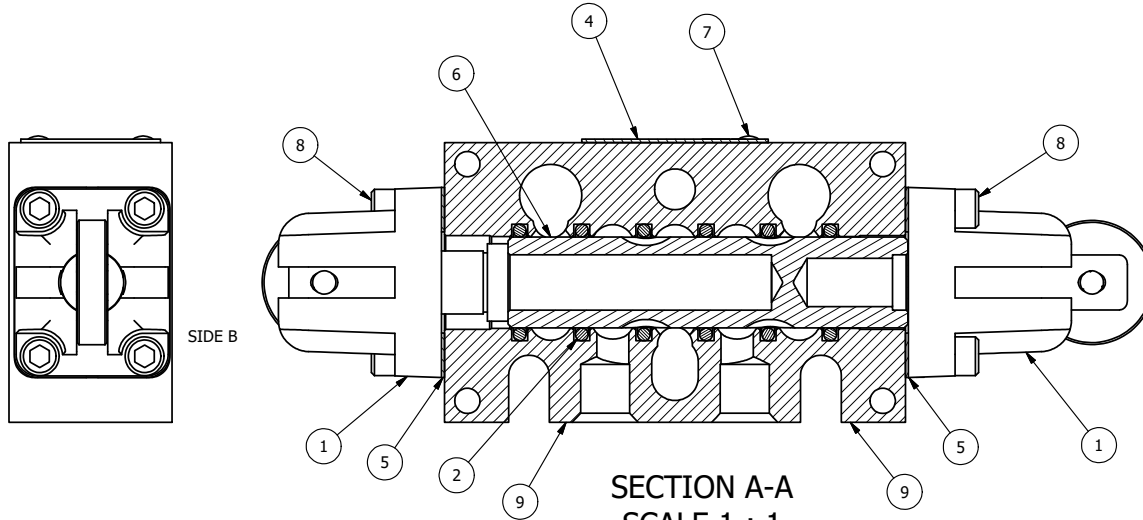

SIDE A

FLG	QTY	PART NO	DESCRIPTION
9	1	B2-10E	FINISHED - SOLID BODY, UPPER PILOTS, 1/4" STACKING VALVE
8	8	V-38	SCREW, 10-24 X 3/4, SOCKET HEAD CAP
7	2	V-212	SCREW, #2 X 3/16 DRIVE, TYPE U, OVAL HEAD, STAINLESS STEEL
6	1	S3	SPOOL - STANDARD, 2 POS, CLSD CTR, 1/4" & 3/8" VALVE
5	2	ECG3	GASKET - END CAP, 1/4" & 3/8" VALVE
4	1	AN-115	BLANK NAMEPLATE FOR HE,KE,KD,RR,D,CR,PP,SR,SS VALVES.
3	3	V-110	O-RING, BUNA-N, 70 DURO, AS-114, (REF 5/8 X 13/16 X 3/32), 1/4" SLEEVE, 1/2" SUB, STACK
2	6	V-39	O-RING, VITON, STD BODY, 1/4" & 3/8" VALVES
1	2	AY-C3R	CAM OPERATOR ASSEMBLY, ROTATED, 1/4" & 3/8" VALVES

NOTES:  
1) ALWAYS GIVE VALVE MODEL AND PART NUMBER WHEN ORDERING PARTS.

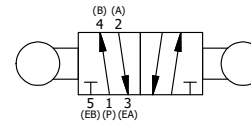

LIMITS ON DIMENSIONS UNLESS OTHERWISE SPECIFIED		2-PL DECIMAL ± .01 3-PL DECIMAL ± .005 FRACTIONAL ± 1/64 ANGULAR ± 1/2°		<b>AAA PRODUCTS INTERNATIONAL</b> 7114 Harry Hines Blvd Dallas, TX 75235
DRAWN: RMckenna		DATE: 9/25/2014		
SCALE: 1:1		SHEET: 1 OF 1		RELEASED: HWomack
TITLE: <b>1/4" STACK, CAM ROLLER, 2 POS, FRICTION POS, CAM RTRN</b>		PART NO.: <b>BCC2</b>		REV.:

THE INFORMATION CONTAINED WITHIN THIS DOCUMENT IS PROPRIETARY TO AAA PRODUCTS AND MAY NOT BE DISCLOSED WITHOUT PRIOR WRITTEN CONSENT

P:\Engineering\product\Valve Assembly\CAD\BCC2.dwg